

A photograph of a wooden floor with a desk lamp, a stack of books, and a pair of glasses in the upper left corner. The text 'I Legni' is centered in the upper half, and 'ARMONIE' is centered in the lower half.

# I Legni

COLLECTION

ARMONIE



ARMONIE



# I Legni

## L'ESSENZA DELL'ABITARE

Collezione ricercata ed originale, I Legni trae ispirazione dal rovere naturale nella sua purezza, ne riproduce l'essenza con straordinaria fedeltà di dettagli e sfumature. Una scelta stilistica che riporta alla memoria suggestioni dimenticate, dove superfici accoglienti e luminose si prestano ad ambientazioni moderne, a spazi residenziali o commerciali regalando un'atmosfera naturale e un appeal contemporaneo.

The essence of living  
L'essence de l'habitat  
Die Essenz des wohnens

The sophisticated and original I Legni collection draws inspiration from natural oak in its pure form and faithfully reproduces its essence in extraordinary detail and colour. A stylistic choice reminiscent of by-gone memories where comforting, light-filled surfaces fit seamlessly into modern settings, and residential or commercial spaces creating a natural atmosphere and contemporary appeal.

Collection recherchée et originale, I Legni tire son inspiration du chêne naturel dans sa pureté, dont elle reproduit l'essence avec une fidélité extraordinaire de détails et de nuances. Un choix stylistique font remonter des suggestions oubliées, où des surfaces accueillantes et lumineuses se prêtent à des décorations modernes, à des espaces résidentiels ou commerciaux en offrant une atmosphère naturelle et un charme contemporain.

Als raffinierte und originelle Kollektion lässt sich I Legni von natürlicher Eiche in ihrer Reinheit inspirieren und reproduziert diese Holzart mit außergewöhnlicher Detailtreue und Nuancen. Eine stilistische Wahl, die vergessene Wirkungen wieder ins Gedächtnis ruft, wo einladende und leuchtende Oberflächen sich für moderne Umgebungen, Wohn- oder Geschäftsräume eignen und eine natürliche Atmosphäre und einen zeitgemäßen Reiz verleihen.



### COLORI E FORMATI

I Legni è un progetto articolato presentato in 3 varianti: Elegance, Natural e Intense e in due essenze calde ed estremamente naturali.

**Elegance** presenta una superficie raffinata, visivamente più uniforme, si presta ad ambientazioni moderne, accoglienti e luminose.

**Natural** è caratterizzata da leggere nodosità che ispirano una semplicità calda ed elegante.

**Intense** si presenta più viva e mutevole, ricca di nodi e venature che ne enfatizzano l'essenza legnosa.

#### Colours and formats

I Legni is a project that comes in 3 variations: Elegance, Natural and Intense and in two warm, highly natural wood effects.

**Elegance** features an elegant, visually even surface, ideal for modern, cosy and light-filled settings.

**Natural** incorporates subtle knots that inspire a warm and elegant simplicity.

**Intense** is more vibrant and variable, filled with knots and veins that emphasise its wood effect.

#### Couleurs et formats

I Legni est un projet articulé présenté en 3 variantes: Elegance, Natural et Intense et en deux essences chaudes et extrêmement naturelles.

**Elegance** présente une surface raffinée, visuellement plus uniforme, qui se prête aux décorations modernes, accueillantes et lumineuses.

**Natural** est caractérisée par de légères nodosités qui suscite une simplicité chaude et élégante.

**Intense** est plus vive et variable, riche en nœuds et veines qui accentuent son essence ligneuse.

#### Farben und Größen

I Legni ist ein artikuliertes Projekt, das in 3 Varianten präsentiert wird: Elegance, Natural und Intense und in zwei warmen und extrem natürlichen Holzarten.

**Elegance** präsentiert eine raffinierte Oberfläche, optisch einheitlicher, ideal für moderne, einladende und helle Umgebungen.

**Natural** zeichnet sich durch leichte Knorrigkeit aus, die eine warme und elegante Schlichtheit inspirieren.

**Intense** ist lebendiger und wechselhafter, voller Äste und Adern, die ihr holziges Wesen betonen.

# Design & Colors

ELEGANCE

NATURAL

INTENSE



BEIGE

WALNUT





Pav\_1 Legni Elegance Beige  
Pav Esterno\_1 Legni Beige Grip  
Riv\_Deco Art Savage





## I Legni Elegance

Gres in massa

Rettificato - Rectified - Rectifié - Rektifiziert  
R10 B - Grip R11 C

UNI EN 14411 - G Bla



30x120 cm  
X 9,5 mm



20x120 cm  
X 9,5 mm



# I Legni Elegance



## BEIGE

- 0698011 30x120
- 0698001 20x120
- 0698002 20x120 Grip



## WALNUT

- 0698012 30x120
- 0698003 20x120
- 0698004 20x120 Grip



Riv\_Loop Bosco  
Pav\_I Legni Elegance Beige





## I Legni Natural

Gres in massa

Rettificato - Rectified - Rectifié - Rektifiziert  
R10 B - Grip R11 C

UNI EN 14411 - G Bla



30x120 cm  
x 9,5 mm



20x120 cm  
x 9,5 mm



## I Legni Natural



### BEIGE

0698013 30x120  
0698005 20x120  
0698006 20x120 Grip



### WALNUT

0698014 30x120  
0698007 20x120  
0698008 20x120 Grip







## I Legni Intense

Gres in massa

Rettificato - Rectified - Rectifié - Rektifiziert  
R10 B

UNI EN 14411 - G Bla



30x120 cm  
x 9,5 mm



20x120 cm  
x 9,5 mm



# I Legni Intense



**BEIGE**

0698015 30x120  
0698009 20x120



**WALNUT**

0698016 30x120  
0698010 20x120





# Deco Art



0451031 RAIN FOREST  
120x120  
Composizione: 2 pz. A+B - 60x120



0451037 TEMPTATION  
120x120  
Composizione: 2 pz. A+B - 60x120



0451015 EDEN  
120x120  
Composizione: 2 pz. A+B - 60x120



0451011 POP GARDEN  
120x120  
Composizione: 2 pz. A+B - 60x120



0451040 BAMBU SKETCH  
120x120  
Composizione: 2 pz. A+B - 60x120



0451042 WONDERLAND  
120x120  
Composizione: 2 pz. A+B - 60x120



0451064 WILDFLOWERS  
120x120  
Composizione: 2 pz. A+B - 60x120



0451036 LILIUM  
120x120  
Composizione: 2 pz. A+B - 60x120



0451012 GOLDEN LEAVES  
120x120  
Composizione: 2 pz. A+B - 60x120



0451001 SAVAGE  
120x120  
Composizione: 2 pz. A+B - 60x120



0451038 FANCY WALL  
120x120  
Composizione: 2 pz. A+B - 60x120



0451033 PURPLE CHIC  
120x120  
Composizione: 2 pz. A+B - 60x120



0451016 MEMORIE  
120x120  
Composizione: 2 pz. A+B - 60x120



0451003 POETICA  
120x120  
Composizione: 2 pz. A+B - 60x120



0451014 BLACK FLOWERS  
120x120  
Composizione: 2 pz. A+B - 60x120



0451004 ROMANCE  
60x120



0451059 CLOROFILLA  
120x120  
Composizione: 2 pz. A+B - 60x120



0451039 MACROPHILLA  
120x120  
Composizione: 2 pz. A+B - 60x120



0451035 COTTON GARDEN  
120x120  
Composizione: 2 pz. A+B - 60x120



0451034 WILD ATELIER  
120x120  
Composizione: 2 pz. A+B - 60x120



0451002 CHARME  
120x120  
Composizione: 2 pz. A+B - 60x120



0451013 GRAFFITI  
120x120  
Composizione: 2 pz. A+B - 60x120



0451017 GOLD LINE CEMENTO  
120x120  
Composizione: 2 pz. A+B - 60x120



0451018 GOLD LINE ARDESIA  
120x120  
Composizione: 2 pz. A+B - 60x120



0451063 VENUS  
120x120  
Composizione: 2 pz. A+B - 60x120



0451032 INCANTO  
120x120  
Composizione: 2 pz. A+B - 60x120

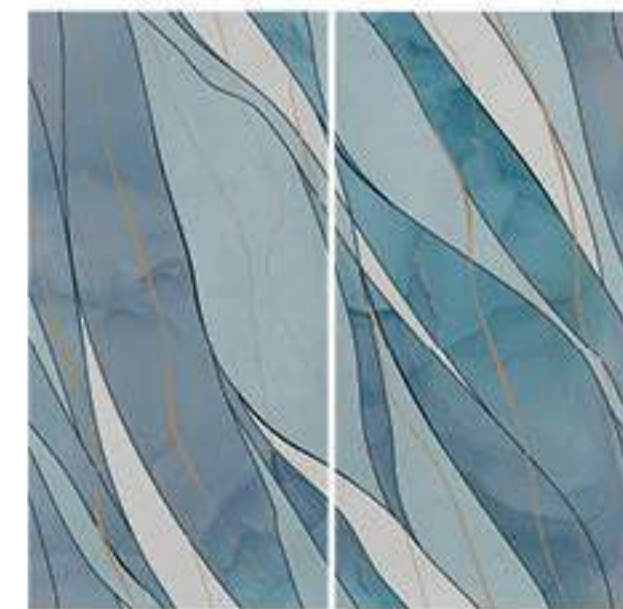

0451041 ICELAND  
120x120  
Composizione: 2 pz. A+B - 60x120



0451005 PAINT  
60x120



# I Legni 2.0

L'ABITARE SENZA CONFINI

Listoni di legno in 2 cm di spessore permettono continuità visiva tra lo spazio interno e gli esterni. I Legni 2.0 svela una matericità sorprendente, dove essenze e sfumature naturali riflettono la luce con leggeri chiaroscuri; una superficie grip che consente di rivestire aree non coperte e di viverle in completa sicurezza.

#### Living without Limits

The wooden planks with thickness of 2cm allow visual continuity between the interior space and the exterior.

Legni 2.0 are a perfect and comfortable material; with a natural design, the light brings out different light and dark shades by showcasing a modern, yet essential style to the surfaces. Moreover, it's a non-slip wood flooring so it can be installed outdoors making the outside area safe for everyone, yet essential style to the surfaces.

#### Vivre sans frontières

Des planches de bois de 2 cm d'épaisseur permettent une continuité visuelle entre l'espace intérieur et l'extérieur.

I Legni 2.0 révèle une matérialité surprenante, où les essences et les nuances naturelles reflètent la lumière avec de légers clairs-obscur; une surface de préhension qui vous permet de couvrir des zones non couvertes et de les vivre en toute sécurité.

#### Vivre sans frontières

Des planches de bois de 2 cm d'épaisseur permettent une continuité visuelle entre l'espace intérieur et l'extérieur.

I Legni 2.0 révèle une matérialité surprenante, où les essences et les nuances naturelles reflètent la lumière avec de légers clairs-obscur; une surface de préhension qui vous permet de couvrir des zones non couvertes et de les vivre en toute sécurité.



# I Legni 2.0

Gres in massa

Rettificato - Rectified - Rectifié - Rektifiziert  
Grip R11 C

UNI EN 14411 - G Bla



30x120 cm  
X 20 mm



## I Legni Elegance 2.0



**BEIGE**  
0698017 30x120



**WALNUT**  
0698018 30x120

## I Legni Natural 2.0



**BEIGE**  
0698019 30x120





**WALNUT**  
0698020 30x120



# I Legni Elegance

PEZZI SPECIALI / Special pieces / Pièces spéciales / Formteile

			
6,5x120 BATTISCOPIA	30x120 GRADONE STEP	30x120x5 ELEMENTO "L"	
Pc. box	6	3	2
BEIGE	0698021	0698027	0698033
WALNUT	0698022	0698028	0698034

Vendita solo a scatole complete / To be sold as full box only / Vendable uniquement en boites entières / Abnahme nur volle Pakete.

CARATTERISTICHE TECNICHE / Technical features / Caractéristiques techniques / Technische Eigenschaften



Scivolosità: Metodo della rampa calzato \ Skid resistance: Shood Ramp Test	Scivolosità: Metodo della rampa a piedi nudi / Skid resistance: Barefoot Ramp Test	Scivolosità: Metodo del pendolo / Skid resistance: Pendolum Friction Test	Scivolosità: Coefficiente di attrito / Skid resistance: Coefficient of Friction (COF)	Scivolosità: Coefficiente di attrito dinamico / Skid resistance: Dynamic Coefficient of friction (DCOF)
R10	B	Class C2	> 0,40 Dry > 0,40 Wet	> 0,42 Wet
R11 GRIP	C	Class C3	> 0,40 Dry > 0,40 Wet	> 0,42 Wet

IMBALLI / Packages / Emballages / Verpackungen

	SCATOLE / Boxes / Boites / Kartons			PALETTE / Pallets / Palettes / Paletten			
	pz.	mq	kg	box	mq	kg	± mm
30x120	4	1,44	35	32	46,08	1120	9,5
20x120	6	1,44	32,91	36	51,84	1185	9,5

# I Legni Natural

PEZZI SPECIALI / Special pieces / Pièces spéciales / Formteile

			
6,5x120 BATTISCOPIA	30x120 GRADONE STEP	30x120x5 ELEMENTO "L"	
Pc. box	6	3	2
BEIGE	0698023	0698029	0698035
WALNUT	0698024	0698030	0698036

Vendita solo a scatole complete / To be sold as full box only / Vendable uniquement en boites entières / Abnahme nur volle Pakete.

CARATTERISTICHE TECNICHE / Technical features / Caractéristiques techniques / Technische Eigenschaften



Scivolosità: Metodo della rampa calzato \ Skid resistance: Shood Ramp Test	Scivolosità: Metodo della rampa a piedi nudi / Skid resistance: Barefoot Ramp Test	Scivolosità: Metodo del pendolo / Skid resistance: Pendolum Friction Test	Scivolosità: Coefficiente di attrito / Skid resistance: Coefficient of Friction (COF)	Scivolosità: Coefficiente di attrito dinamico / Skid resistance: Dynamic Coefficient of friction (DCOF)
R10	B	Class C2	> 0,40 Dry > 0,40 Wet	> 0,42 Wet
R11 GRIP	C	Class C3	> 0,40 Dry > 0,40 Wet	> 0,42 Wet

IMBALLI / Packages / Emballages / Verpackungen

	SCATOLE / Boxes / Boites / Kartons			PALETTE / Pallets / Palettes / Paletten			
	pz.	mq	kg	box	mq	kg	± mm
30x120	4	1,44	35	32	46,08	1120	9,5
20x120	6	1,44	32,91	36	51,84	1185	9,5

# I Legni Intense

PEZZI SPECIALI / Special pieces / Pièces spéciales / Formteile

			
6,5x120 BATTISCOPIA	30x120 GRADONE STEP	30x120x5 ELEMENTO "L"	
Pc. box	6	3	2
BEIGE	0698025	0698031	0698037
WALNUT	0698026	0698032	0698038

Vendita solo a scatole complete / To be sold as full box only / Vendable uniquement en boites entières / Abnahme nur volle Pakete.

CARATTERISTICHE TECNICHE / Technical features / Caractéristiques techniques / Technische Eigenschaften

Scivolosità: Metodo della rampa calzato \ Skid resistance: Shood Ramp Test	Scivolosità: Metodo della rampa a piedi nudi / Skid resistance: Barefoot Ramp Test	Scivolosità: Metodo del pendolo / Skid resistance: Pendolum Friction Test	Scivolosità: Coefficiente di attrito / Skid resistance: Coefficient of Friction (COF)	Scivolosità: Coefficiente di attrito dinamico / Skid resistance: Dynamic Coefficient of friction (DCOF)
R10	B	Class C2	> 0,40 Dry > 0,40 Wet	> 0,42 Wet

IMBALLI / Packages / Emballages / Verpackungen

	SCATOLE / Boxes / Boites / Kartons			PALETTE / Pallets / Palettes / Paletten			
	pz.	mq	kg	box	mq	kg	± mm
30x120	4	1,44	35	32	46,08	1120	9,5
20x120	6	1,44	32,91	36	51,84	1185	9,5

# I Legni 2.0

PEZZI SPECIALI / Special pieces / Pièces spéciales / Formteile

	
30x120x2 GRADONE STEP	
Pc. Box	2
ELEGANCE BEIGE	0698039
ELEGANCE WALNUT	0698040
NATURAL BEIGE	0698041
NATURAL WALNUT	0698042

Vendita solo a scatole complete / To be sold as full box only / Vendable uniquement en boites entières / Abnahme nur volle Pakete.

CARATTERISTICHE TECNICHE / Technical features / Caractéristiques techniques / Technische Eigenschaften

Scivolosità: Metodo della rampa calzato \ Skid resistance: Shood Ramp Test	Scivolosità: Metodo della rampa a piedi nudi / Skid resistance: Barefoot Ramp Test	Scivolosità: Metodo del pendolo / Skid resistance: Pendolum Friction Test	Scivolosità: Coefficiente di attrito / Skid resistance: Coefficient of Friction (COF)	Scivolosità: Coefficiente di attrito dinamico / Skid resistance: Dynamic Coefficient of friction (DCOF)
R11	C	Class C3	> 0,40 Dry > 0,40 Wet	> 0,42 Wet

IMBALLI / Packages / Emballages / Verpackungen

	SCATOLE / Boxes / Boites / Kartons			PALETTE / Pallets / Palettes / Paletten			
	pz.	mq	kg	box	mq	kg	± mm
30x120	2	0,72	32,95	36	25,92	1186,2	20



# Deco Art

Decoro con lustri/metalli preziosi utilizzabile a rivestimento. Si consiglia la pulizia con detergenti neutri, non abrasivi. Non pulire energicamente con panni o spugne. È sconsigliata la posa nell'area doccia. Si consiglia di mantenere il senso di posa indicato.  
 Decors with lustres/precious metals used for covering. We recommend cleaning with neutral, non-abrasive detergents. Clean gently using cloth or a sponge. Tiles should not be installed in the shower area. Compliance with the specified laying direction is strongly recommended.  
 Décor avec lustres/métaux précieux à poser sur le mur. Lavage recommandé avec des détergents neutres, non abrasifs. Nettoyez délicatement à l'aide d'un chiffon ou d'une éponge. Pose déconseillée dans la douche. Il est recommandé de conserver le sens de pose indiqué.  
 Dekor mit Glanzelementen/Edelmetallen für die Wandverkleidung. Es wird die Reinigung mit neutralen, scheuermittelfreien Reinigungsmitteln empfohlen. Wischen Sie nicht Kräftig mit Tüchern oder Schwämmen. Die Verlegung in der Duschnische wird nicht empfohlen. Es wird empfohlen, die angegebene Verlegerichtung zu beachten.

	SCATOLE / Boxes / Boites / Kartons			PALETTE / Pallets / Palettes / Paletten			
	pz.	mq	kg	box	mq	kg	± mm
60x120	2	1,44	32	20	28,8	660	10

## Caratteristiche Tecniche

Technical features - Caractéristiques techniques - Technische eigenschaften

GRES PORCELLANATO - UNI EN 14411 - G Bia Porcelain stoneware - Grès cérame - Feinsteinzeug	METODO DI PROVA TEST METHOD	VALORE DICHIARATO DECLARED VALUE Matt	VALORE DICHIARATO DECLARED VALUE Grip	VALORE DICHIARATO DECLARED VALUE 2.0
Resistenza al fuoco Fire resistance	Decisione 96/603/CEE e sue modifiche	A1 <sub>fl</sub>	A1 <sub>fl</sub>	A1 <sub>fl</sub>
Assorbimento d'acqua Water absorption	EN ISO 10545-3	≤0,5%	≤0,5%	≤0,5%
Sforzo di rottura Breaking strenght	EN ISO 10545-4	S ≥ 1300 N	S ≥ 1300 N	S ≥ 1300 N
Modulo di rottura Modul of ropture		R ≥ 35 N/mm <sup>2</sup>	R ≥ 35 N/mm <sup>2</sup>	R ≥ 35 N/mm <sup>2</sup>
Resistenza all'urto Impact resistance	EN ISO 10545-5	>0,80	>0,80	>0,84
Resistenza all'abrasione profonda Abrasion resistance	EN ISO 10545-6	<175mm <sup>3</sup>	<175mm <sup>3</sup>	<175mm <sup>3</sup>
Coefficiente di dilatazione termica lineare Thermal expansion coefficient	EN ISO 10545-8	6,5x10 <sup>-6</sup> /°C	6,5x10 <sup>-6</sup> /°C	6,5x10 <sup>-6</sup> /°C
Resistenza agli sbalzi termici Resistance to thermal shocks	EN ISO 10545-9	Resiste	Resiste	Resiste
Determinazione della dilatazione dovuta all'umidità Determination of moisture expansion	EN ISO 10545-10	0,1mm/m	0,1mm/m	0,1mm/m
Resistenza al gelo Frost resistance	EN ISO 10545-12	Resiste	Resiste	Resiste
Resistenza ai prodotti chimici di uso domestico e agli additivi per piscina Resistance to household chemicals and swimming pool salts	EN ISO 10545-13	A	A	A
Resistenza a basse concentrazioni di acidi e alcali Resistance to low concentration of acids and alkalis		LA	LA	LA
Resistenza ad alte concentrazioni di acidi e alcali Resistance to high concentration of acids and alkalis		HA	HA	HA
Resistenza alle macchie Resistance to stains	EN ISO 10545-14	5	5	5
Scivolosità: Metodo della rampa calzato Skid resistance: Shood Ramp Test	DIN 51130	R 10	R 11	R11
Scivolosità: Metodo della rampa a piedi nudi Skid resistance: Barefoot Ramp Test	DIN 51097	A	C	C
Scivolosità: Metodo del pendolo Skid resistance: Pendolum Friction Test	BS 7976	≥ 36 Dry ≥ 36 Wet	≥ 36 Dry ≥ 36 Wet	≥ 36 Dry ≥ 36 Wet
	AS 4586	Class P3	Class P4	Class P4
	UNE-ENV 12633	Class C2	Class C3	Class C3
Scivolosità: Coefficiente di attrito Skid resistance: Coefficient of Friction (COF)	B.C.R.A. Rep. CEC/81	>0,40 Dry >0,40 Wet	>0,40 Dry >0,40 Wet	>0,40 Dry >0,40 Wet
Scivolosità: Coefficiente di attrito dinamico Skid resistance: Dynamic Coefficient of friction (DCOF)	ANSI DCOF A137.1-2012	>0,42 Wet	>0,42 Wet	>0,42 Wet



# ARMONIE

Via Statale 467 - n.136  
42013 Casalgrande - Reggio Emilia - Italy  
T +39 0536 823 203 - 0536 802 214  
F +39 0536 822 812 - 0536 889 511  
[www.armonieceramiche.com](http://www.armonieceramiche.com)  
[info@armonieceramiche.com](mailto:info@armonieceramiche.com)