

Castlestone



CERAMICHE PIEMME
FLOOR AND MORE

Castlestone



Con Castlestone il fascino della pietra è ora
al servizio dell'arredamento architettonico.

Thanks to Castlestone, the appeal of stone is now
at the service of architectural design.

Mit Castlestone steht der Zauber des Natursteins
heute im Dienst der architektonischen Raumgestaltung.

Avec Castlestone, le charme de la pierre
est maintenant au service de l'architecture d'intérieur.

Colori - Colors

white

80x80cm 31 1/2" x 31 1/2" · 60x60cm 24" x 24" · 30x60cm 12" x 24" · 45x90cm 18" x 36"

almond

80x80cm 31 1/2" x 31 1/2" · 60x60cm 24" x 24" · 30x60cm 12" x 24" · 45x90cm 18" x 36"

grey

80x80cm 31 1/2" x 31 1/2" · 60x60cm 24" x 24" · 30x60cm 12" x 24" · 45x90cm 18" x 36"

musk

80x80cm 31 1/2" x 31 1/2" · 60x60cm 24" x 24" · 30x60cm 12" x 24" · 45x90cm 18" x 36"

black

80x80cm 31 1/2" x 31 1/2" · 60x60cm 24" x 24" · 30x60cm 12" x 24" · 45x90cm 18" x 36"

Strutture - Structures

antislip R11

60x60cm 24" x 24"

strips R11

30x60cm 12" x 24"

muretto

30x60cm 12" x 24"

mix

30x60cm 12" x 24"

inciso

30x60cm 12" x 24"



Castlestone è **perfetta**
per valorizzare gli
spazi contemporanei.
Design, tecnica e creatività
conferiscono agli ambienti
un **fascino senza tempo**.

Castlestone is **perfect** for promoting **contemporary spaces**.
Design, technology and creativity convey a **timeless charm** to interiors.

Castlestone eignet sich **perfekt** zur Aufwertung zeitgenössischer Räume.
Design, Technik und Kreativität verleihen den Räumen **zeitlosen Zauber**.

Castlestone valorise parfaitement les **espaces contemporains**.
Le design, la technique et la créativité apportent à chaque
cadre de vie un **charme intemporel**.

grey nat/ret 45x90 cm - 18"x36"

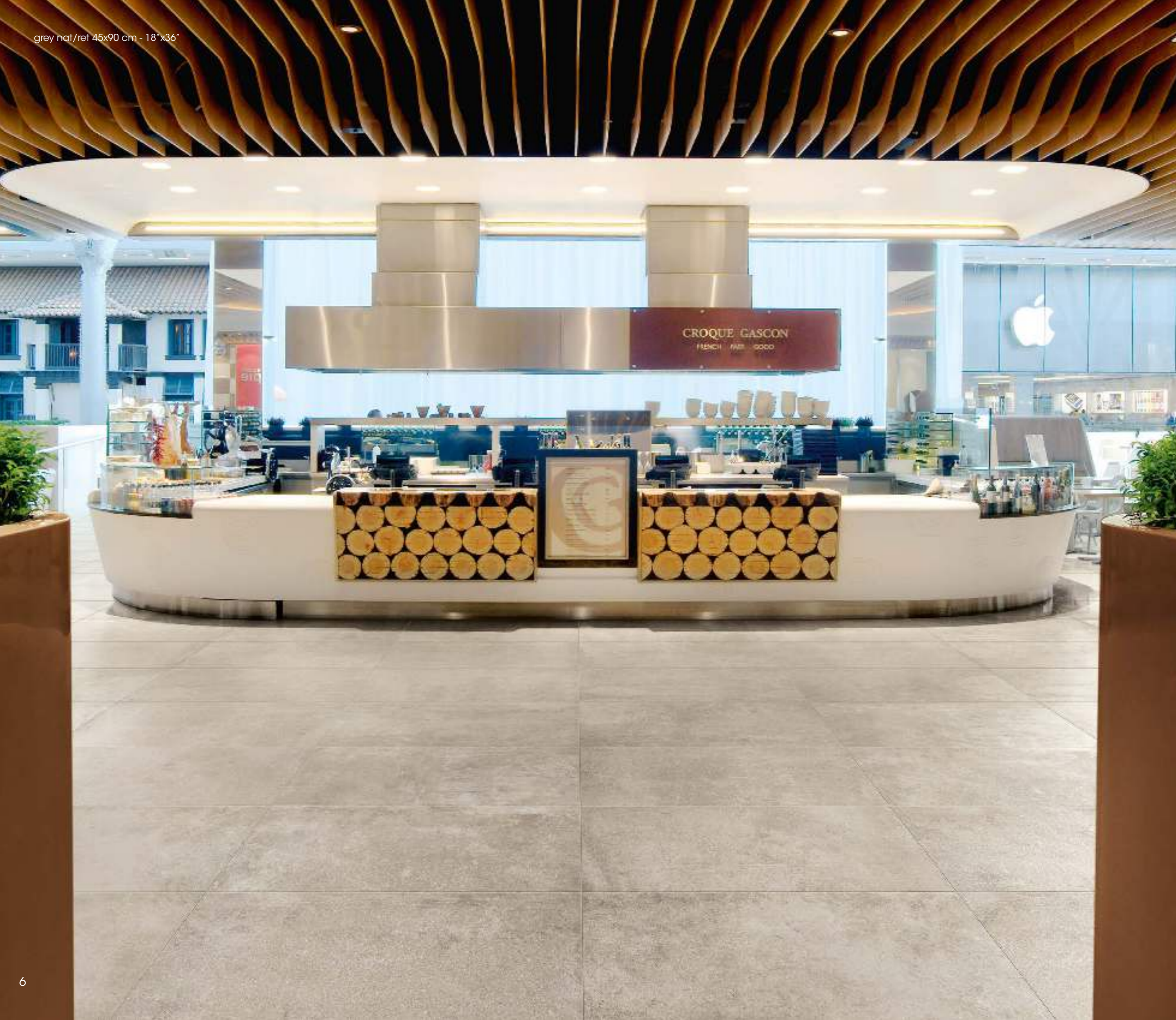

Public Spaces



grey nat/ret 45x90 cm - 18"x36"



white nat/ret 60x60 cm - 24"x24"

Public Spaces



black nat/ret 60x60 cm - 24"x24"



black nat/ret 60x60 cm - 24"x24"



musk nat/ret 60x60 cm - 24"x24"

Castlestone

Materiali che ripercorrono il tempo portando ai giorni nostri l'**essenza del design**, rivisitato nelle linee e nelle geometrie. **Decorazioni uniche** arredano con stile.

Materials that retrace time, conveying to the present day the **essence of design**, reinterpreted in terms of lines and shapes. **One-of-a-kind decorations** furnish with style.

Materialien, die die Zeiten überdauern und uns die **Essenz des Designs** überliefern, in Linien und Geometrien erneuert. **Einzigartige Dekorationen**, die stilvoll einrichten.

Des matières qui remontent le temps pour remettre au goût du jour l'**essence du design**, revu dans ses lignes et dans ses géométries. **Des décors uniques** qui habillent avec style.



Restaurant



almond nat/ret 30x60 cm - 12"x24" / mix warm ret 30x60 cm - 12"x24"

almond nat/ret 60x60 cm - 24"x24" / 30x60 cm - 12"x24"
mix warm ret 30x60 cm - 12"x24"





Castlestone

La luce è restituita negli **infiniti riflessi** delle superfici lappate. **Formati ideali** per comunicare **ampiezza e leggerezza.**

Light is restored in the **endless reflections** of the lapped surfaces. **Ideal sizes** for communicating **amplitude and lightness.**

Das Licht wird in den **unendlichen Reflexen** der geläppten Oberflächen wiedergegeben. **Ideale Formate**, um **Weite** und **Leichtigkeit** zu kommunizieren.

La lumière est rendue dans les **reflets infinis** des surfaces polies. **Les formats expriment au mieux l'ampleur et la légèreté.**

black nat/ret 30x60 cm - 12"x24"



Residential



grey nat/ret 30x60 cm - 12"x24"



grey nat/ret 30x60 cm - 12"x24"

Castlestone

Muretto: una **superficie tridimensionale** ottenuta con **tecnologie d'avanguardia** offre giochi di profondità sempre diversi per un rivestimento multisensoriale.

Muretto: a **three-dimensional surface**, obtained using **cutting-edge technologies**, ensures ever-different depth effects for a multi-sensorial covering.

Muretto: Eine **dreidimensionale Oberfläche** aus **Spitzentechnologien** spielt mit Effekten von immer wieder anderer Tiefe und bildet eine die Sinnen ansprechende Verkleidung.

Muretto: **surface tridimensionnelle** obtenue à l'aide de **technologies d'avant-garde** offrant des jeux de profondeur sans cesse renouvelés pour un revêtement multisensoriel.

muretto almond ret 30x60 cm - 12"x24"



...itazione, poca schiuma, temperatura di cantina
...ALE, PALE ALE, SCOTCH ALE)
...mentazione, colore oro pallido, mediamente amara
...schiuma abbondante, cremosa, gusto amaro.
...gma, dorata, abbondante schiuma, non filtrata

MENU
...CICCOLIA
...PASTELLATI
...ARELINE FRITTE
...E RIFIENE
...and VINEGAR
...ALL'INGLESE
...GLIERI DI SALUMI
...STEL e
...MINI WÜRSTEL



inciso musk ret 30x60 cm - 12"x24"

Bar



Estetica unita ad **elevati standard di sicurezza.**

La superficie antislip mantiene **omogeneità cromatica** rispetto alla superficie naturale.

Aesthetics combined with **high safety standards.**
The non-slip surface maintains **colour uniformity** compared to the natural surface.

Die Verbindung aus Schönheit und **hohem Sicherheitsniveau.**
Die rutschfeste Oberfläche bewahrt im Vergleich zur natürlichen Oberfläche **farbliche Einheitlichkeit.**

L'esthétique jointe à de **hauts standards de sécurité.**
La surface antidérapante conserve une **homogénéité chromatique** par rapport à la surface naturelle.

white nat/ret 60x60 cm - 24"x24" / antislip white ret 60x60 cm - 24"x24"



Antislip



antislip white ret 60x60 cm - 24"x24"

Castlestone

Strips è una superficie tridimensionale antiscivolo che garantisce **maggiore sicurezza in esterno** grazie alle sue particolari scanalature che rievocano la profondità della pietra scalpellata a mano.

Strips is a non-slip three-dimensional surface which ensures **greater outdoor safety** thanks to its particular grooves evoking the depth of hand-cut stone.

Strips ist eine rutschfeste, dreidimensionale Oberfläche, die **größere Sicherheit im Freien garantiert**. Dafür sorgen die besonderen Rillen, die die Tiefe des von Hand behauenen Natursteins nachempfinden.

Strips est une surface tridimensionnelle antiglissante qui assure **plus de sécurité à l'extérieur** grâce à des rainures particulières évoquant la profondeur de la pierre sculptée à la main.



Strips



strips musk ret 30x60 cm - 12"x24"



strips musk ret 30x60 cm - 12"x24"

musk lap/ref 30x60 cm - 12"x24" / strips musk ret 30x60 cm - 12"x24"





Massimo **coordinamento stilistico**
fra interno ed esterno, grazie alla
versione in spessore 20mm
che offre **praticità e sicurezza**.

Utmost **design coordination** between indoors and outdoors
thanks to the 20 mm thick version providing **practicality** and **safety**.

Maximale **stilistische Abstimmung** zwischen Innen- und Außenräumen,
dank der Version in 20 mm Stärke, die besonders **praktisch und sicher** ist.

Coordination stylistique maximale entre l'intérieur et l'extérieur grâce
à la version de 20 mm d'épaisseur joignant la **sécurité** à l'aspect **pratique**.



20mm



almond grip/ret 45x90 cm - 18"x36" spessore 20mm

Colori e Formati

Sizes and colors - Formate und Farben - Formats et couleurs

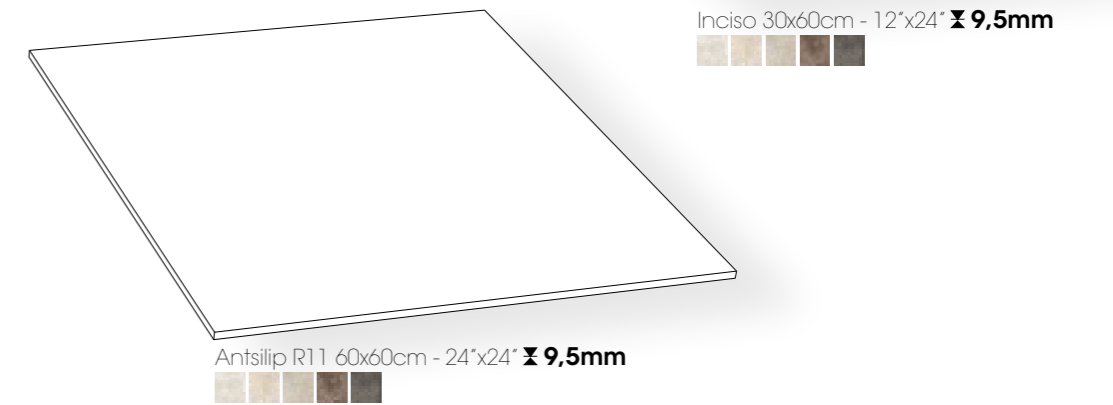
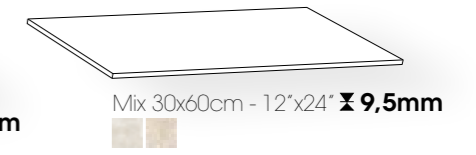
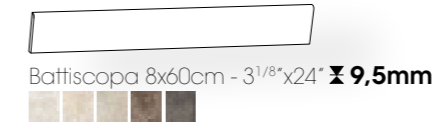
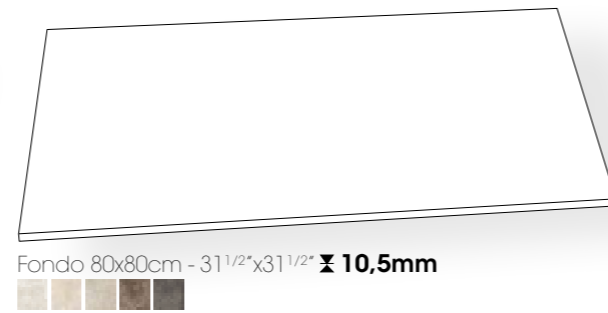
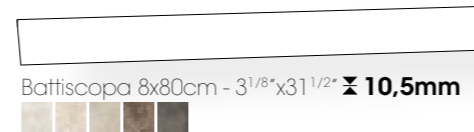
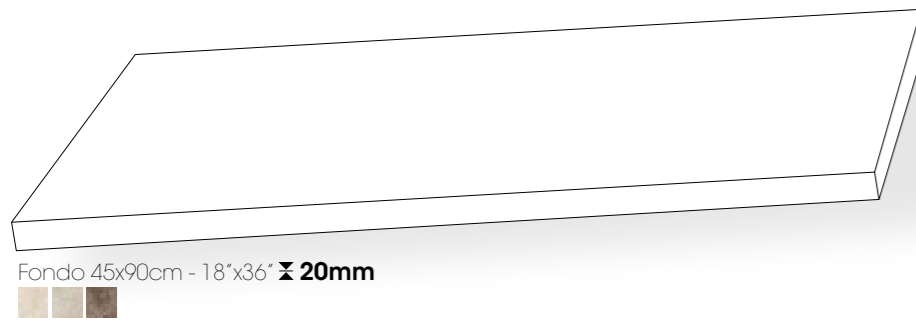
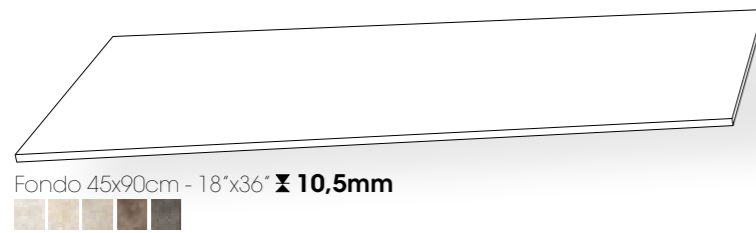
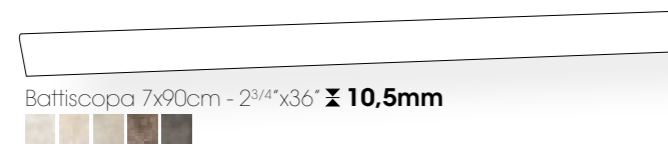

White

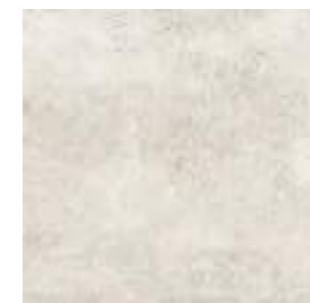

Almond



Grey

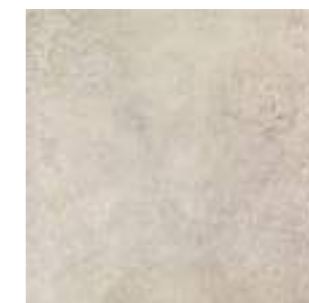

Musk



Black



White

GRES FINE PORCELLANATO AD IMPASTO COLORATO
COLOURED-BODY FINE PORCELAIN STONEWARE
FEINSTEINZEUG AUS FARBIGER MASSE
GRÈS CÉRAME FIN À PÂTE COLORÉE

TECNOLOGIA DIGITALE
DIGITAL TECHNOLOGY
DIGITALTECHNOLOGIE
TECHNOLOGIE NUMÉRIQUE

60x60 cm 24"x24"
30x60 cm 12"x24"
9,5 mm

45x90 cm 18"x36"
10,5 mm



00126 CASTLESTONE WHITE NAT/RET U4 P4 E3 C2 **56**
00131 CASTLESTONE WHITE LAP/RET **67**
60x60 - 24"x24" V3



00456 CASTLESTONE WHITE ANTISLIP RET R11 **57**
60x60 - 24"x24"



00159 MOSAICO WHITE RET **16**
30x30 - 12"x12" (pz box 5)



*00164 CASTLESTONE WHITE NAT/RET
01108 CASTLESTONE WHITE NAT/RET
*00169 CASTLESTONE WHITE LAP/RET
01113 CASTLESTONE WHITE LAP/RET
45x90 - 18"x36"



U4 P4 E3 C2 **60**
69
V3

00136 CASTLESTONE WHITE NAT/RET U4 P3 E3 C2 **51**
00142 CASTLESTONE WHITE LAP/RET **64**
30x60 - 12"x24" V3



00154 CASTLESTONE WHITE STRIPS RET R11 **62**
30x60 - 12"x24" V3



00149 CASTLESTONE MURETTO WHITE RET **64**
30x60 - 12"x24"



00224 CASTLESTONE MIX COLD RET **56**
30x60 - 12"x24"



00282 CASTLESTONE INCISO WHITE RET **64**
30x60 - 12"x24" mix 2 pezzi (pz box 6)

*Attenzione: l'imballo del formato 45x90 può essere da 2 o 3 pezzi. Verificare in fase di ordine.
Attention: the packing of size 45x90 could be 2 pieces in box or 3 pieces in box. Kindly check while ordering.
Achtung: die Verpackungen vom Format 45x90 können entweder 2 oder 3 Stk. enthalten. Bitte prüfen Sie es bei jeder Bestellung.
Attention: le conditionnement du format 45x90 peut être de 2 ou 3 pièces par boîte. Merci de vérifier en phase de commande s'il vous plaît.

Almond

GRES FINE PORCELLANATO AD IMPASTO COLORATO
COLOURED-BODY FINE PORCELAIN STONEWARE
FEINSTEINZEUG AUS FARBIGER MASSE
GRÈS CÉRAME FIN À PÂTE COLORÉE

TECNOLOGIA DIGITALE
DIGITAL TECHNOLOGY
DIGITALTECHNOLOGIE
TECHNOLOGIE NUMÉRIQUE

60x60 cm 24"x24"
30x60 cm 12"x24"
9,5 mm

45x90 cm 18"x36"
10,5 mm



00127 CASTLESTONE ALMOND NAT/RET U4 P4 E3 C2 56
00132 CASTLESTONE ALMOND LAP/RET 67
60x60 - 24"x24" V3



00457 CASTLESTONE ALMOND ANTISLIP RET R11 57
60x60 - 24"x24"



00160 MOSAICO ALMOND RET 16
30x30 - 12"x12" (pz box 5)



*00165 CASTLESTONE ALMOND NAT/RET
01109 CASTLESTONE ALMOND NAT/RET
*00170 CASTLESTONE ALMOND LAP/RET
01114 CASTLESTONE ALMOND LAP/RET
45x90 - 18"x36"

U4 P4 E3 C2 60
69
V3



00137 CASTLESTONE ALMOND NAT/RET U4 P3 E3 C2 51
00145 CASTLESTONE ALMOND LAP/RET 64
30x60 - 12"x24" V3



00155 CASTLESTONE ALMOND STRIPS RET R11 62
30x60 - 12"x24" V3



00150 CASTLESTONE MURETTO ALMOND RET 64
30x60 - 12"x24"



00225 CASTLESTONE MIX WARM RET 56
30x60 - 12"x24"



00283 CASTLESTONE INCISO ALMOND RET 64
30x60 - 12"x24" mix 2 pezzi (pz box 5)

*Attenzione: l'imballo del formato 45x90 può essere da 2 o 3 pezzi. Verificare in fase di ordine.
Attention: the packing of size 45x90 could be 2 pieces in box or 3 pieces in box. Kindly check while ordering.
Achtung: die Verpackungen vom Format 45x90 können entweder 2 oder 3 Stk. enthalten. Bitte prüfen Sie es bei jeder Bestellung.
Attention: le conditionnement du format 45x90 peut être de 2 ou 3 pièces par boîte. Merci de vérifier en phase de commande s'il vous plaît.

Grey

GRES FINE PORCELLANATO AD IMPASTO COLORATO
COLOURED-BODY FINE PORCELAIN STONEWARE
FEINSTEINZEUG AUS FARBIGER MASSE
GRÈS CÉRAME FIN À PÂTE COLORÉE

TECNOLOGIA DIGITALE
DIGITAL TECHNOLOGY
DIGITALTECHNOLOGIE
TECHNOLOGIE NUMÉRIQUE

60x60 cm 24"x24"
30x60 cm 12"x24"
9,5 mm

45x90 cm 18"x36"
10,5 mm



00128 CASTLESTONE GREY NAT/RET U4 P4 E3 C2 **56**
00133 CASTLESTONE GREY LAP/RET **67**
60x60 - 24"x24" V3



00458 CASTLESTONE GREY ANTISLIP RET R11 **57**
60x60 - 24"x24"



00161 MOSAICO GREY RET **16**
30x30 - 12"x12" (pz box 5)



*00166 CASTLESTONE GREY NAT/RET
01110 CASTLESTONE GREY NAT/RET
*00171 CASTLESTONE GREY LAP/RET
01115 CASTLESTONE GREY LAP/RET
45x90 - 18"x36"

U4 P4 E3 C2 **60**
69
V3

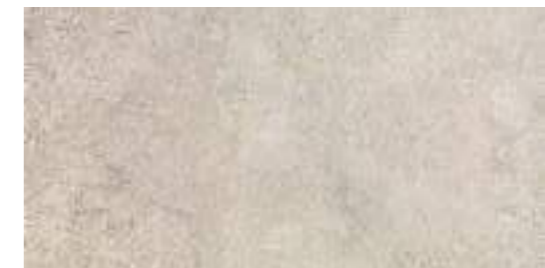

00138 CASTLESTONE GREY NAT/RET U4 P3 E3 C2 **51**
00146 CASTLESTONE GREY LAP/RET **64**
30x60 - 12"x24" V3



00156 CASTLESTONE GREY STRIPS RET R11 **62**
30x60 - 12"x24" V3



00151 CASTLESTONE MURETTO GREY RET **64**
30x60 - 12"x24"



00224 CASTLESTONE MIX COLD RET **56**
30x60 - 12"x24"



00284 CASTLESTONE INCISO GREY RET **64**
30x60 - 12"x24" mix 2 pezzi (pz box 6)

*Attenzione: l'imballo del formato 45x90 può essere da 2 o 3 pezzi. Verificare in fase di ordine.
Attention: the packing of size 45x90 could be 2 pieces in box or 3 pieces in box. Kindly check while ordering.
Achtung: die Verpackungen vom Format 45x90 können entweder 2 oder 3 Stk. enthalten. Bitte prüfen Sie es bei jeder Bestellung.
Attention: le conditionnement du format 45x90 peut être de 2 ou 3 pièces par boîte. Merci de vérifier en phase de commande s'il vous plaît.

Musk

GRES FINE PORCELLANATO AD IMPASTO COLORATO
COLOURED-BODY FINE PORCELAIN STONEWARE
FEINSTEINZEUG AUS FARBIGER MASSE
GRÈS CÉRAMÉ FIN À PÂTE COLORÉE

TECNOLOGIA DIGITALE
DIGITAL TECHNOLOGY
DIGITALTECHNOLOGIE
TECHNOLOGIE NUMÉRIQUE

60x60 cm 24"x24"
30x60 cm 12"x24" 9,5 mm
45x90 cm 18"x36" 10,5 mm



00129 CASTLESTONE MUSK NAT/RET U4 P4 E3 C2 **56**
00134 CASTLESTONE MUSK LAP/RET **67**
60x60 - 24"x24" V3



00459 CASTLESTONE MUSK ANTISLIP RET R11 **57**
60x60 - 24"x24"



00162 MOSAICO MUSK RET **16**
30x30 - 12"x12" (pz box 5)



*00167 CASTLESTONE MUSK NAT/RET
01111 CASTLESTONE MUSK NAT/RET
*00172 CASTLESTONE MUSK LAP/RET
01116 CASTLESTONE MUSK LAP/RET
45x90 - 18"x36"

U4 P4 E3 C2 **60**
69
V3



00139 CASTLESTONE MUSK NAT/RET U4 P3 E3 C2 **51**
00147 CASTLESTONE MUSK LAP/RET **64**
30x60 - 12"x24" V3



00157 CASTLESTONE MUSK STRIPS RET R11 **62**
30x60 - 12"x24" V3



00152 CASTLESTONE MURETTO MUSK RET **64**
30x60 - 12"x24"



00225 CASTLESTONE MIX WARM RET **56**
30x60 - 12"x24"



00285 CASTLESTONE INCISO MUSK RET **70**
30x60 - 12"x24" mix 2 pezzi (pz box 5)

musk nat/ret 60x60 cm - 24"x24"

*Attenzione: l'imballo del formato 45x90 può essere da 2 o 3 pezzi. Verificare in fase di ordine.
Attention: the packing of size 45x90 could be 2 pieces in box or 3 pieces in box. Kindly check while ordering.
Achtung: die Verpackungen vom Format 45x90 können entweder 2 oder 3 Stk. enthalten. Bitte prüfen Sie es bei jeder Bestellung.
Attention: le conditionnement du format 45x90 peut être de 2 ou 3 pièces par boîte. Merci de vérifier en phase de commande s'il vous plait.

Black

GRES FINE PORCELLANATO AD IMPASTO COLORATO
COLOURED-BODY FINE PORCELAIN STONEWARE
FEINSTEINZEUG AUS FARBIGER MASSE
GRÈS CÉRAME FIN À PÂTE COLORÉE

TECNOLOGIA DIGITALE
DIGITAL TECHNOLOGY
DIGITALTECHNOLOGIE
TECNOLOGIE NUMÉRIQUE

60x60 cm
24"x24"
30x60 cm
12"x24"

45x90 cm
18"x36"

9,5 mm
10,5 mm



00130 CASTLESTONE BLACK NAT/RET U4 P4 E3 C2 **56**
00135 CASTLESTONE BLACK LAP/RET **67**
60x60 - 24"x24" V3



00460 CASTLESTONE BLACK ANTISLIP RET **R11 57**
60x60 - 24"x24"



00163 MOSAICO BLACK RET **16**
30x30 - 12"x12" (pz box 5)



*00168 CASTLESTONE BLACK NAT/RET
01112 CASTLESTONE BLACK NAT/RET
*00173 CASTLESTONE BLACK LAP/RET
01117 CASTLESTONE BLACK LAP/RET
45x90 - 18"x36"

U4 P4 E3 C2 **60**
69
V3



00141 CASTLESTONE BLACK NAT/RET U4 P3 E3 C2 **51**
00148 CASTLESTONE BLACK LAP/RET **64**
30x60 - 12"x24" V3



00158 CASTLESTONE BLACK STRIPS RET **R11 62**
30x60 - 12"x24" V3



00153 CASTLESTONE MURETTO BLACK RET **64**
30x60 - 12"x24"



00224 CASTLESTONE MIX COLD RET **56**
30x60 - 12"x24"



00286 CASTLESTONE INCISO BLACK RET **70**
30x60 - 12"x24" mix 2 pezzi (pz box 6)

*Attenzione: l'imballo del formato 45x90 può essere da 2 o 3 pezzi. Verificare in fase di ordine.
Attention: the packing of size 45x90 could be 2 pieces in box or 3 pieces in box. Kindly check while ordering.
Achtung: die Verpackungen vom Format 45x90 können entweder 2 oder 3 Stk. enthalten. Bitte prüfen Sie es bei jeder Bestellung.
Attention: le conditionnement du format 45x90 peut être de 2 ou 3 pièces par boîte. Merci de vérifier en phase de commande s'il vous plait.

Maxi Formati

Maxi Sizes - Maxiformate - Maxi Formats

GRES FINE PORCELLANATO AD IMPASTO COLORATO
COLOURED-BODY FINE PORCELAIN STONWARE
FEINSTEINZEUG AUS FARBIGER MASSE
GRÈS CÉRAME FIN À PÂTE COLORÉE

TECNOLOGIA DIGITALE
DIGITAL TECHNOLOGY
DIGITALTECHNOLOGIE
TECHNOLOGIE NUMÉRIQUE

80x80 cm
31 1/2" x 31 1/2"

10,5 mm

GRES FINE PORCELLANATO AD IMPASTO COLORATO
COLOURED-BODY FINE PORCELAIN STONWARE
FEINSTEINZEUG AUS FARBIGER MASSE
GRÈS CÉRAME FIN À PÂTE COLORÉE

TECNOLOGIA DIGITALE
DIGITAL TECHNOLOGY
DIGITALTECHNOLOGIE
TECHNOLOGIE NUMÉRIQUE

80x80 cm
31 1/2" x 31 1/2"

10,5 mm

White



00461 CASTLESTONE WHITE NAT/RET U4 P3 E3 C2 73
00467 CASTLESTONE WHITE LAP/RET 76
80x80 - 31 1/2" x 31 1/2" V3

Almond



00462 CASTLESTONE ALMOND NAT/RET U4 P3 E3 C2 73
00468 CASTLESTONE ALMOND LAP/RET 76
80x80 - 31 1/2" x 31 1/2" V3

Grey



00463 CASTLESTONE GREY NAT/RET U4 P3 E3 C2 73
00469 CASTLESTONE GREY LAP/RET 76
80x80 - 31 1/2" x 31 1/2" V3

Musk



00464 CASTLESTONE MUSK NAT/RET U4 P3 E3 C2 73
00470 CASTLESTONE MUSK LAP/RET 76
46 80x80 - 31 1/2" x 31 1/2" V3

Black



00466 CASTLESTONE BLACK NAT/RET U4 P3 E3 C2 73
00471 CASTLESTONE BLACK LAP/RET 76
80x80 - 31 1/2" x 31 1/2" V3

20mm

GRES FINE PORCELLANATO
PORCELAIN STONEWARE
FEINSTEINZEUG
GRÈS CÉRAME

TECNOLOGIA DIGITALE
DIGITAL TECHNOLOGY
DIGITALTECHNOLOGIE
TECHNOLOGIE NUMÉRIQUE

45x90 cm
18"x36"

20 mm

Pezzi Speciali 20mm
Special Pieces 20mm - Formteile 20mm - Pièces Spéciales 20mm

Almond R11



00485 CASTLESTONE ALMOND GRIP/RET R11 79
45x90 - 18"x36"

Grey R11



00486 CASTLESTONE GREY GRIP/RET R11 79
45x90 - 18"x36"

Musk R11



00487 CASTLESTONE MUSK GRIP/RET R11 79
45x90 - 18"x36"

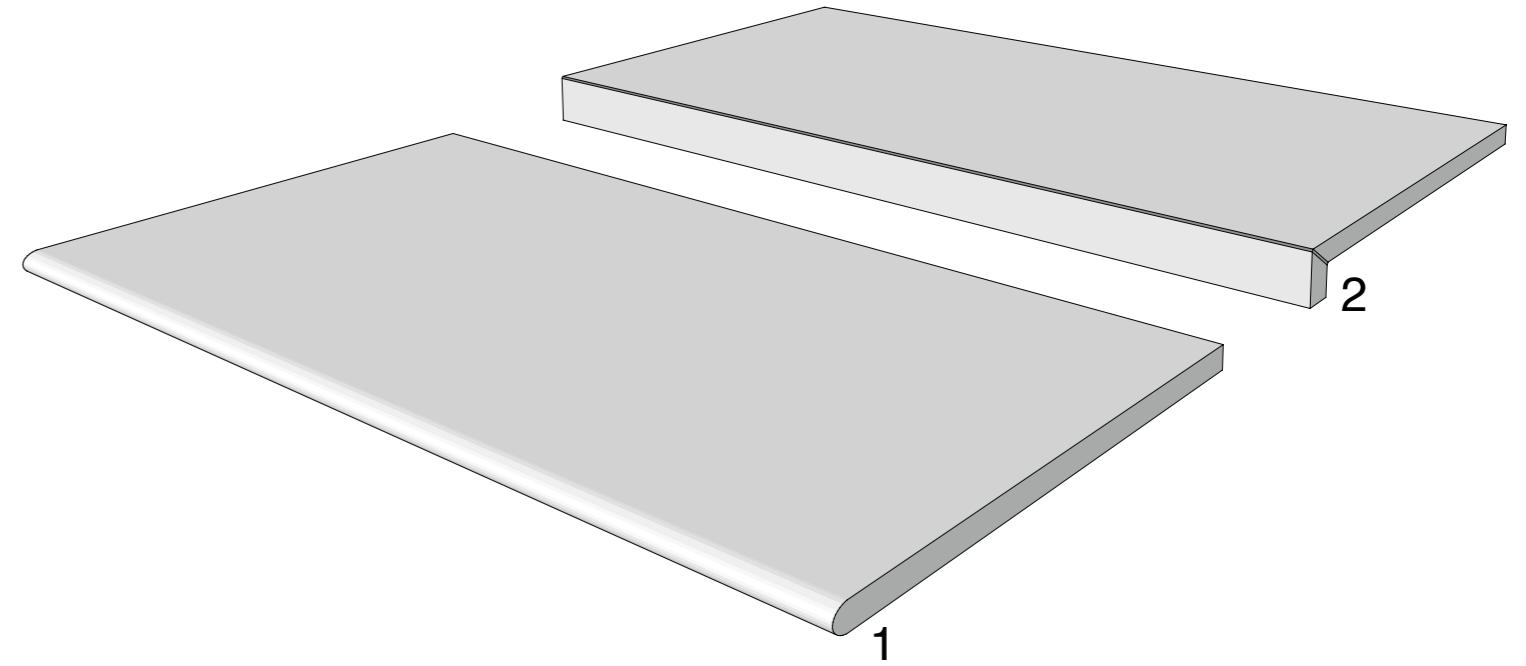

1 GRADONE 45x90cm	pz. box:2	2 ELEMENTO AD L 30x90cm	pz. box:2
00568 GRADONE ALMOND GRIP/RET	83	00565 ELEM. AD L ALMOND GRIP/RET	83
00569 GRADONE GREY GRIP/RET	83	00566 ELEM. AD L GREY GRIP/RET	83
00570 GRADONE MUSK GRIP/RET	83	00567 ELEM. AD L MUSK GRIP/RET	83

Piemme 20mm

Piemme amplia la gamma produttiva introducendo il nuovo spessore 20mm. L'estrema versatilità di questo nuovo materiale consente di soddisfare ogni esigenza progettuale per l'outdoor. Piemme 20mm è una nuova superficie di design, resistente, sicura ed inalterabile nel tempo.

Piemme is extending its product range with the new 20 mm thickness. The extreme versatility of this new material permits catering to all outdoor planning requirements. Piemme 20mm is a new design surface, strong, reliable and unchanging over time.

Die Firma Piemme erweitert ihre Produktionspalette durch Einführung der neuen 20-mm-Stärke. Die extreme Vielseitigkeit dieses neuen Materials erlaubt es, allen Entwurfserfordernissen für Freiräume gerecht zu werden. Piemme 20 mm ist eine neue widerstandsfähige, sichere und der Zeit trotzende Designeroberfläche.

Piemme élargit sa gamme de production en ajoutant une nouvelle épaisseur: 20 mm. La grande polyvalence de ce nouveau matériau permet de répondre à toutes les exigences de l'aménagement extérieur. Piemme 20 mm est une nouvelle surface de design, résistante, fiable et inaltérable dans le temps.

Destinazioni d'uso - Intended uses Verwendungszwecke - Domaines d'application

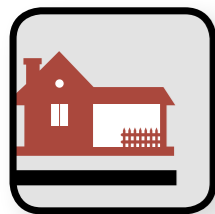

Vialetti
Walkways
Wege
Allées

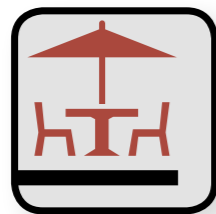

Terrazze
Terraces
Terrassen
Terrasses

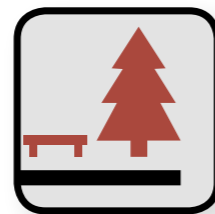

Parchi pubblici
Public parks
Öffentliche Parks
Parcs publics

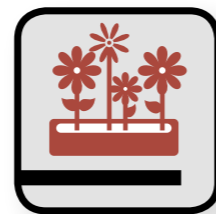

Giardini
Gardens
Gärten
Jardins



Parcheggi
Parking areas
Parkplätze
Parkings

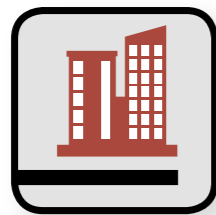

Arredo urbano
Street furnishing
Stadtmoöbiliar
Ameublement urbain



Zone industriali
Industrial areas
Industriebereiche
Espaces Industriels



Stabilimenti balneari
Beach resorts
Badeanlagen
Stations balnéaires

Applicazioni - Applications Verlegungsbeispiele - Applications



Posa a secco su erba, ghiaia e sabbia - Dry laying on grass, gravel and sand
Trockene Verlegung auf Gras, auf Kies und Splitt, auf Sand - Pose à sec sur herbe, gravier et sable



Posa su massetto con colla - Laying on screed with adhesive
Traditionelle Verlegung auf Estrich - Pose à la colle sur dalle



Posa sopraelevata - Laying as raised paving
Trockene Verlegung auf Stützen - Pose surélevée

Pezzi Speciali

Special Pieces - Formteile - Pièces Spéciales

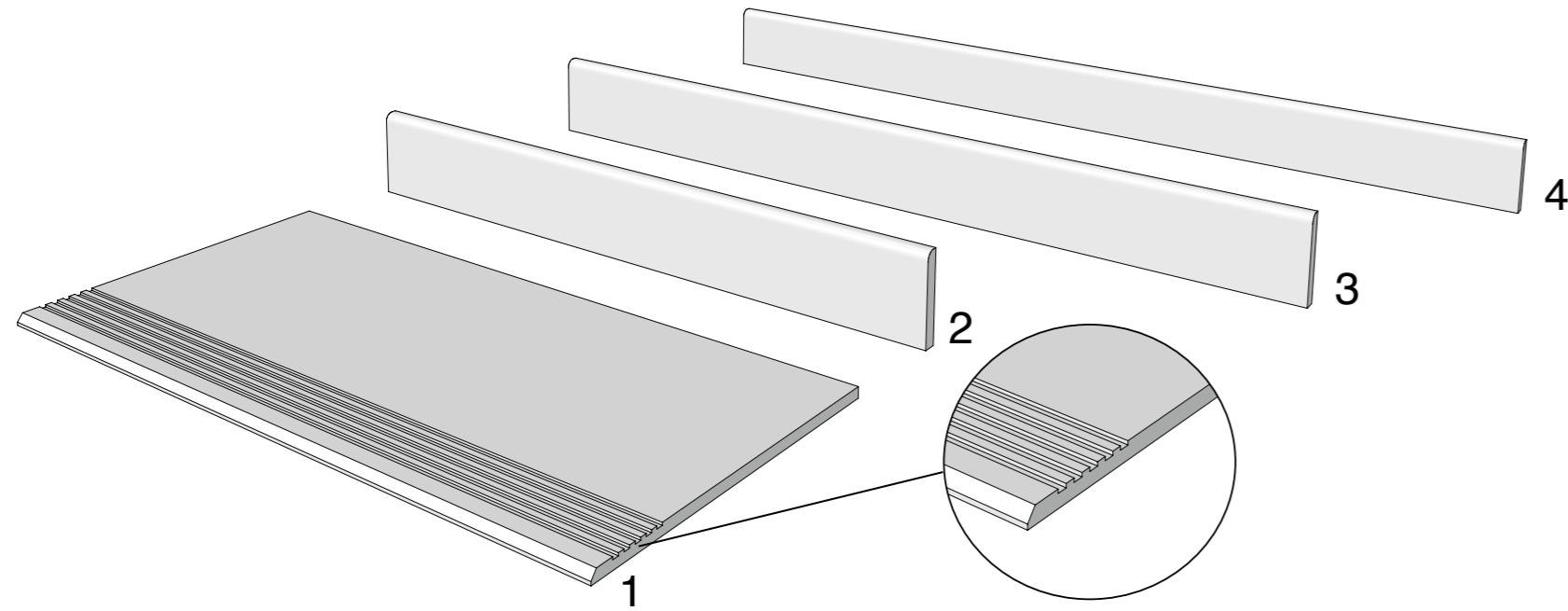

1 GRADINO 30x60cm pz. box:6

00189	GRADINO WHITE NAT/RET	▲20
00194	GRADINO WHITE LAP/RET	▲26
00190	GRADINO ALMOND NAT/RET	▲20
00195	GRADINO ALMOND LAP/RET	▲26
00191	GRADINO GREY NAT/RET	▲20
00196	GRADINO GREY LAP/RET	▲26
00192	GRADINO MUSK NAT/RET	▲20
00197	GRADINO MUSK LAP/RET	▲26
00193	GRADINO BLACK NAT/RET	▲20
00198	GRADINO BLACK LAP/RET	▲26

2 BATTISCOPA 8x60cm pz. box:10

00179	BATTISCOPA WHITE NAT/RET	▲8
00184	BATTISCOPA WHITE LAP/RET	▲13
00180	BATTISCOPA ALMOND NAT/RET	▲8
00185	BATTISCOPA ALMOND LAP/RET	▲13
00181	BATTISCOPA GREY NAT/RET	▲8
00186	BATTISCOPA GREY LAP/RET	▲13
00182	BATTISCOPA MUSK NAT/RET	▲8
00187	BATTISCOPA MUSK LAP/RET	▲13
00183	BATTISCOPA BLACK NAT/RET	▲8
00188	BATTISCOPA BLACK LAP/RET	▲13

3 BATTISCOPA 8x80cm pz. box:7

00472	BATTISCOPA WHITE NAT/RET	▲10
00477	BATTISCOPA WHITE LAP/RET	▲15
00473	BATTISCOPA ALMOND NAT/RET	▲10
00478	BATTISCOPA ALMOND LAP/RET	▲15
00474	BATTISCOPA GREY NAT/RET	▲10
00479	BATTISCOPA GREY LAP/RET	▲15
00475	BATTISCOPA MUSK NAT/RET	▲10
00480	BATTISCOPA MUSK LAP/RET	▲15
00476	BATTISCOPA BLACK NAT/RET	▲10
00481	BATTISCOPA BLACK LAP/RET	▲15

4 BATTISCOPA 7x90cm pz. box:8

00199	BATTISCOPA WHITE NAT/RET	▲13
00204	BATTISCOPA WHITE LAP/RET	▲20
00200	BATTISCOPA ALMOND NAT/RET	▲13
00205	BATTISCOPA ALMOND LAP/RET	▲20
00201	BATTISCOPA GREY NAT/RET	▲13
00206	BATTISCOPA GREY LAP/RET	▲20
00202	BATTISCOPA MUSK NAT/RET	▲13
00207	BATTISCOPA MUSK LAP/RET	▲20
00203	BATTISCOPA BLACK NAT/RET	▲13
00208	BATTISCOPA BLACK LAP/RET	▲20

Imballi

Packing - Verpackung - Emballage

FORMATI SIZES	SPessori THICKNESS	SUPERFICIE SURFACE	WHITE	ALMOND	GREY	MUSK	BLACK	IMBALLI PACKING	Pezzi/Scatola Pcs/Box Stk./Karton Carreaux/Bolles	Mq/Scatola Sqmt/Box M2/Karton Om/Bolles	Kg/Scatola Kgs/Box Kg/Karton Kg/Bolles	Scatola/Paletta Boxes/Pallet Karton/Palette Bolles/Pallet	Mq/Paletta Sqmt/Pallet M2/Palette Om/Pallet	Kg/Paletta Kgs/Pallet Kg/Palette Kg/Pallet
			●	●	●	●	●							
80x80 / 31"12"x31"12"	10,5mm	NAT / RET	●	●	●	●	●		2	1,280	31,50	40	51,20	1260
		LAP / RET	●	●	●	●	●		2*	0,810	19,50	40	32,40	780
45x90 / 18"x36"	10,5mm	NAT / RET	●	●	●	●	●		3	1,220	29,00	30	36,60	870
		LAP / RET	●	●	●	●	●		2	0,810	36,00	24	19,44	864
45x90 / 18"x36"	20mm	GRIP / RET R11	-	●	●	●	-							
60x60 / 24"x24"	9,5mm	NAT / RET	●	●	●	●	●		3	1,080	21,50	40	43,20	860
		LAP / RET	●	●	●	●	●							
ANTISLIP 60x60 / 24"x24"	9,5mm	RET R11	●	●	●	●	●		3	1,080	21,50	40	43,20	860
30x60 / 12"x24"	9,5mm	NAT / RET	●	●	●	●	●		6	1,080	21,50	48	51,84	1032
		LAP / RET	●	●	●	●	●							
STRIPS 30x60 / 12"x24"	9,5mm	RET R11	●	●	●	●	●		6	1,080	21,50	48	51,84	1032
MURETTO 30x60 / 12"x24"	9,5mm	RET	●	●	●	●	●		6	1,080	21,50	40	43,20	860
INCISO 30x60 / 12"x24"	9,5mm	RET	●	●	●	●	●		6	1,080	21,50	48	51,84	1032
MIX 30x60 / 12"x24"	9,5mm	RET	MIX COLD / MIX WARM						6	1,080	21,50	48	51,84	1032
MOSAICO 30x30 / 12"x12"	9,5mm	RET	●	●	●	●	●	5	0,450	8,50	60	-	-	
PEZZI SPECIALI / SPECIAL PIECES														
GRADINO 30x60 / 12"x24"	9,5mm	NAT / RET	●	●	●	●	●		6	1,080	21,50	48	-	-
		LAP / RET	●	●	●	●	●							
BATTISCOPA 8x60 / 3"18"x24"	9,5mm	NAT / RET	●	●	●	●	●		10	0,480 ml 6,00	11,00	72	-	-
		LAP / RET	●	●	●	●	●							
BATTISCOPA 8x80 / 3"18"x31"12"	10,5mm	NAT / RET	●	●	●	●	●		7	0,450 ml 5,60	11,00	65	-	-
		LAP / RET	●	●	●	●	●							
BATTISCOPA 7x90 / 2"81"x36"	10,5mm	NAT / RET	●	●	●	●	●		8	0,504 ml 7,20	13,00	48	-	-
		LAP / RET	●	●	●	●	●							
GRADONE 45x90 / 18"x36"	20mm	GRIP / RET R11	-	●	●	●	-		2	0,810	35,00	24	-	-
ELEMENTO AD L 30x90 / 12"x36"	20mm	GRIP / RET R11	-	●	●	●	-		2	0,540	24,00	24	-	-

*Attenzione: l'imballo del formato 45x90 può essere da 2 o 3 pezzi. Verificare in fase di ordine.
 Attention: the packing of size 45x90 could be 2 pieces in box or 3 pieces in box. Kindly check while ordering.
 Achtung: die Verpackungen vom Format 45x90 können entweder 2 oder 3 Stk. enthalten. Bitte prüfen Sie es bei jeder Bestellung.
 Attention: le conditionnement du format 45x90 peut être de 2 ou 3 pièces par boîte. Merci de vérifier en phase de commande s'il vous plait.

Gli spessori riportati in questo catalogo sono nominali e possono variare a seconda dei formati e delle finiture.
 The thickness mentioned on this catalogue are nominal and can be different according to the sizes and the finishes.
 Die angegebene Fliesenstärke sind Nominal und können verschieden sein je nach Format oder Oberfläche.
 Les épaisseurs reportées sur ce catalogue sont nominales et peuvent varier suivant les formats et les finitions.

Per una migliore resa estetica Piemme consiglia stuccature colorate in tinta con le piastrelle.
 For a better aesthetic finish, Piemme recommends using jointing colours that match the tiles.
 Für ein optisch perfektes Ergebnis empfiehlt Piemme, die Fugen farblich auf die Fliesen abzustimmen.
 Pour parfaire l'effet esthétique obtenu, Piemme conseille de confectionner des joints de la même couleur que les carreaux.

Per i prodotti rettificati consigliamo una fuga di 2 mm per un migliore risultato di posa.
 For better installation results of rectified products, we suggest 2 mm joint.
 Damit sich eine bessere Verlegung von geschliffenen Produkten ergibt, empfehlen wir eine Fugenbreite von 2 mm.
 Pour obtenir le meilleur résultat de pose de produits rectifiés, il est conseillé de réaliser un joint de 2 mm.



■ Fascia prezzo al metro quadro Square meter price range Quadratmeter preisgruppe Niveau de prix au mètre carré	▲ Fascia prezzo al pezzo Price range per piece Stück preisgruppe Niveau de prix à la pièce	▣ Spessore mm Thickness mm Stärke mm Épaisseur mm
--	---	--

Le tonalità dei colori sono indicative
 The colour shades are indicative
 Die farbtöne sind annähernd
 Les tonalités des couleurs sont indicatives

Caratteristiche Tecniche

Technical Characteristics - Technische Daten - Caracteristiques Techniques

Classificazione secondo norme CEN/ISO gruppo B1a EN 14411 - Iso 13006 - Classification in accordance with CEN/ISO standards B1a EN 14411 - Iso 13006
 Klassifizierung gemäß CEN/ISO-Normen Gruppe B1a EN 14411 - Iso 13006 - Classification selon les normes CEN/ISO groupe B1a EN 14411 - Iso 13006

Caratteristica Tecnica Technical Characteristic Technische Date Caractéristique Technique	Norma Norm Norm Norme	Valore prescritto Value required Normvorgabe Valeur prescrite	Valore medio Mean value Mittelwert Valeur moyenne	USA tests	Valore medio Mean value Mittelwert Valeur moyenne
					
Lunghezza e larghezza Length and width / Länge und Breite / Longueur et largeur	ISO 10545.2	±0,6% (±2,00 mm)	Conforme In accordance Erfüllt Conforme	ASTM C-499 ASTM C-485 ASTM C-502	In accordance
Spessore Thickness / Stärke / Epaisseur		±5% (±0,5 mm)			
Rettilineità lati Warpages of edges / Geradheit der Kanten / Réctitude des arêtes		±0,5% (±1,5 mm)			
Ortogonalità Wedging / Rechtwinkligkeit / Orthogonalité		±0,5% (±2,00 mm)			
Planarità Flatness / Planität / Planimétrie		±0,5% (±2,00 mm)			
Assorbimento % d'acqua Water absorption Wasseraufnahme % Absorption d'eau %	ISO 10545.3	≤ 0,5%	Conforme In accordance Erfüllt Conforme	ASTM C-373	In accordance
Resistenza alla flessione Bending strength Biegezugfestigkeit Résistance à la flexion	ISO 10545.4	≥ 35N/mm ²	Conforme In accordance Erfüllt Conforme	ASTM C-648 250 LBS or greater	In accordance
Dilatazione termica lineare tra 20° e 100° C Linear thermal expansion between 20° and 100° C Lineare Wärmeausdehnung zwischen 20° und 100° C Dilatation thermique linéaire entre 20° et 100° C	ISO 10545.8	Secondo i dati del costruttore According to builder's specifications Lautangaben des Herstellers Selon les éléments du constructeur	≈ 7x10 ⁻⁶ C ⁻¹		
Resistenza agli sbalzi termici Thermal shock resistance Temperaturwechselbeständigkeit Résistance aux écarts de température	ISO 10545.9	Richiesta Request Bitte Demande	Resistente Resistant Widerstehend Résistant		
Resistenza al gelo Frost resistance Frostbeständigkeit Résistance au gel	ISO 10545.12	Richiesta Request Bitte Demande	Resistente Resistant Widerstehend Résistant	ASTM C-1026	In accordance
Resistenza all'attacco chimico Resistance to chemical attack Beständigkeit gegen Chemikalien Résistance à l'attaque chimique	ISO 10545.13	Secondo i dati del costruttore According to builder's specifications Lautangaben des Herstellers Selon les éléments du constructeur	Resistente Resistant Widerstehend Résistant	ASTM C-650	In accordance
Resistenza dei colori alla luce Colours resistance to light Lichtbeständigkeit Résistance des couleurs à la lumière	DIN 51094	Nessuna alterazione No alteration Keine Veränderung Aucune altération	Conforme In accordance Erfüllt Conforme		
Resistenza alle macchie Stain resistance Fleckenfestigkeit Résistance aux taches	ISO 10545.14	≥ Classe 3 Metodo di prova disponibile Test method available Verfügbare prüfmethod Méthode d'essai disponible	Conforme In accordance Erfüllt Conforme		
Resistenza allo scivolamento Slippage resistance Rutschsicherheit Résistance au glissement	DIN 51130 *	9 ≤ R ≤ 13	NAT R10 LAP STRIPS R11 ANTISLIP R11 20MM R11	ASTM C-1028 * COF ≥ 0,6 Dry ≥ 0,6 Wet	NAT Dry / Wet > 0.6 LAP STRIPS Dry / Wet > 0.6 ANTISLIP 20MM
	DIN 51097 *	A,B,C	NAT A LAP STRIPS A+B+C ANTISLIP 20MM A+B+C	ANSI * 137.1-2012 DCOF > 0,42 Wet	NAT > 0.42 LAP STRIPS > 0.42 ANTISLIP 20MM
Pendulum slip test	BS EN 7976-2*	> 36 Dry > 36 Wet	NAT LAP STRIPS ANTISLIP 20MM		

*Trattandosi di normative nazionali, i metodi di prova, i requisiti e le classificazioni variano da paese a paese. Il valore atteso dalla resistenza allo scivolamento della produzione di Industrie Ceramiche Piemme S.p.a., può variare in base al lotto produttivo. Specifica documentazione è disponibile su richiesta.
 Test methods, requirements and classifications differ from country to country, according to the national regulations. The expected value of slippage resistance of products by Industrie Ceramiche Piemme S.p.a. may vary depending on the production batch. Specific documents are available upon request.
 Prüfverfahren, Erfordernisse und Klassifikationen sind verschieden von Land zu Land, gemäß der nationalen Vorschriften. Der Erwartungswert der Rutschsicherheit der Produkte von Industrie Ceramiche Piemme S.p.a. kann sich - je nach der Produktionspartie - verändern. Spezifische Unterlagen sind auf Verlangen zur Verfügung.
 Les méthodes d'essai, les réquisitions et les classifications changent de pays à pays, selon les réglementations nationales. La valeur attendue de résistance au glissement des produits de Industrie Ceramiche Piemme S.p.a. peut varier en fonction du lot de production. Une documentation spécifique est disponible sur demande.

ELENCO DELLE SERIE CERTIFICATE E CLASSIFICAZIONI DISPONIBILI A RICHIESTA - LIST OF CERTIFIED SERIES AND CLASSIFICATIONS AVAILABLE UPON REQUEST
 LISTE DER GEPRÜFTEN SERIE UND KLASIFIZIERUNGEN AUF ANFRAGE ERHÄLTICH - LISTE DES SERIES CERTIFIÉES ET DES CLASSEMENTS DISPONIBLES SUR DEMANDE



CERAMICHEPIEMME
FLOOR AND MORE



Norme per la posa e la manutenzione

Installation and maintenance instructions - Verlegung, reinigung und pflege
 Guide a la pose et l'entretien

<ul style="list-style-type: none"> - Per i prodotti rettificati consigliamo una fuga di 2 mm per un migliore risultato di posa. - Per una migliore resa estetica Piemme consiglia stuccature colorate in tinta con le piastrelle. - Verificare, prima dell'utilizzo, la compatibilità ed idoneità dei riempitivi per fughe con il prodotto ceramico. - Rimuovere le eccedenze dei riempitivi per fughe quando gli stessi sono ancora freschi. - Attenersi scrupolosamente alle istruzioni indicate dai produttori dei riempitivi per fughe. - Per eliminare completamente i residui di posa, che potrebbero compromettere la manutenzione ordinaria e le caratteristiche del prodotto, a posa ultimata, procedere con la pulizia utilizzando prodotti adeguati, a base Acida max 3%, rispettando le indicazioni del produttore. Osservare assolutamente i limiti di tempo indicati nelle istruzioni: un contatto troppo prolungato con questi prodotti potrebbe provocare il danneggiamento della superficie. - Gli eventuali aloni che si dovessero presentare dopo la posa di materiali lappati o levigati si potranno facilmente eliminare utilizzando un prodotto idoneo, a base Alcalina. - Riguardo l'utilizzo di materiali ceramici all'esterno, pure riconfermando l'ingelività dei prodotti Piemme in gres porcellanato, in conformità alle vigenti normative europee EN 14411/ISO 13006-ISO 10545.12, occorre attenersi ad alcune fondamentali norme previste per la posa all'esterno, atte a rendere inattaccabili al gelo i predetti pavimenti. Le condizioni più importanti da rispettare sono: le opportune pendenze, le impermeabilizzazioni, i giunti di dilatazione, e l'uso di idonei materiali per la posa. - Decorazioni realizzati con smalti e metalli preziosi E' indispensabile proteggere la superficie durante la posa, non utilizzare assolutamente prodotti abrasivi e/o acidi, ma solo acqua e sapone neutro. Il produttore non risponde di eventuali danni a questi preziosi materiali causati da "sfregamenti" durante la posa in opera. Per nessun motivo saranno accettate contestazioni relative a materiale posato. 	<p>TIPO DI SPORCO</p> <p>Birra - Caffè - Gelato - Vino Gomma Pneumatico - Grassi vegetali e animali - Inchiostri - Lampositi Olii Meccanici - Residui di scotch Olio di lino - Pennarello - Resine Smalti - Tintura per capelli</p> <p>INDICAZIONI PER LA PULIZIA</p> <p>Prodotti a Base Alcalina</p> <p>Cera protettiva anti-abrasione Depositi calcarei Macchie di ruggine</p> <p>Prodotti a Base Acida</p> <p>Cera di candela Residui di scotch</p> <p>Solventi</p> <p>Per ulteriori informazioni specifiche consultare l'area tecnica sul sito Piemme: www.ceramichepiemme.it</p>
<ul style="list-style-type: none"> - For better installation results of rectified products, we suggest 2 mm joint. - For a better aesthetic finish, Piemme recommends using jointing colours that match the tiles. - Please check, before using, the compatibility and suitability of grouting material with the ceramic tile. - Clean away the excess of grouting materials while they are still fresh. - Follow carefully the instructions pointed out by the producers of tile grouting materials. - To completely eliminate installation residues, which could negatively affect routine maintenance and product characteristics once installation has terminated, proceed to clean using adequate products, with max. 3% Acid base, following the manufacturer's instructions. Always closely abide by the time limits indicated in the instructions: prolonged contact with these products may cause damage to the surface. - Any rims that appear after installing lapped or polished materials can be easily eliminated using a suitable Alkaline-based product. - With regard to the use of ceramic materials outdoors, while once more reiterating that Piemme porcelain stoneware products are frost-proof, in compliance with applicable European standards EN 14411/ISO 13006-ISO 10545.12, a number of fundamental procedures must be followed for outdoor installation, suitable for making the aforementioned floors resistant to frost. The most important aspects are: suitable gradients, waterproofing, expansion joints, and the use of suitable installation materials. - Decorations made with glazes and precious metals It is most important to protect the surface during installation. Never use abrasive and/or acid products, only water and neutral soap. The manufacturer disclaims liability in case of any damage to these precious materials caused by "rubbing" during installation. Under no circumstances will disputes be accepted relating to the installed material. 	<p>TYPE OF STAIN</p> <p>beer - coffee - wine - ice cream vegetable and animal fats - rubber remains of scotch tape - grease from machines - linseed oil - felt tip pens - paints - inks - hair dye</p> <p>CLEANING SUGGESTIONS</p> <p>Alkaline-based detergent</p> <p>protective anti-abrasion wax calcareous residuals rust stains</p> <p>Acid-based detergent</p> <p>candle wax remains of scotch-tape</p> <p>Solvent</p> <p>For further specific details please visit the technical area on Piemme website: www.ceramichepiemme.it</p>
<ul style="list-style-type: none"> - Damit sich eine bessere Verlegung von geschliffenen Produkten ergibt, empfehlen wir eine Fugenbreite von 2 mm. - Für ein optisch perfektes Ergebnis empfiehlt Piemme, die Fugen farblich auf die Fliesen abzustimmen. - Prüfen sie bitte, vor der Verwendung, die Zweckmäßigkeit und die Verträglichkeit des Fugenfüllmittels mit den Keramikfliesen. - Bitte entfernen sie das überflüssige Fugenfüllmittel wenn es noch frisch ist. - Folgen sie bitte sorgfältig die von dem Herstellern des Fugenfüllmittels angegebenen Bedienungsvorschriften. - Zur vollkommenen Entfernung der Verlegerückstände, die die normale Pflege erschweren und die Merkmale des Produkts beeinträchtigen könnten, nach der Verlegung geeignete Reinigungsmittel auf max. 3% Säurebasis verwenden und bei der Reinigung die Hinweise des Herstellers beachten. Die angegebenen Zeiten keinesfalls überschreiten: ein zu lange andauernder Kontakt mit diesen Produkten kann Beschädigungen der Oberfläche verursachen. - Eventuelle nach der Verlegung von geläpftem oder geschliffenem Material sichtbare Schleier lassen sich einfach mit entsprechenden, alkalischen Produkten entfernen. - Auch wenn die Piemme-Feinsteinzeugprodukte gemäß den europäischen Normen EN 14411/ISO 13006-ISO 10545.12 frostbeständig sind, müssen beim Einsatz keramischer Materialien im Freien einige Grundregeln beachtet werden, damit die Bodenbeläge nicht vom Frost angegriffen werden können. Die wichtigsten Voraussetzungen sind: korrektes Gefälle, Abdichtung, Dehnungsfugen sowie geeignetes Verlegematerial. - Dekore mit Glasuren und Edelmetallen Während der Verlegung muss die Oberfläche unbedingt abgedeckt werden. Es dürfen keine scheuernden und/oder säurehaltigen Produkte verwendet werden, sondern ausschließlich Wasser und neutrale Seife. Der Hersteller haftet nicht für eventuelle, während der Verlegung durch Abrieb entstandene Schäden an diesen hochwertigen Materialien. Reklamationen von bereits verlegtem Material werden in keinem Fall akzeptiert. 	<p>VERSCHMUTZUNGSART</p> <p>Bier - Wein - Eis - Kaffee Tierische oder pflanzliche Fette Gummi - Kleberbandresten Schmieröl - Tinte - Leöl - Filzstift - Harz oder Lack - Haarfarbe</p> <p>REINIGUNGSHINWEISE</p> <p>Alkalische Reinigungsmittel</p> <p>Kratzschutz-Wachs Kalkablagerungen Rostflecken</p> <p>Säure-Reinigungsmittel</p> <p>Kerzenwachs Kleberbandresten</p> <p>Lösungsmittel</p> <p>Weitere Einzelheiten finden Sie in dem technischen Bereich des Piemme Website: www.ceramichepiemme.it</p>
<ul style="list-style-type: none"> - Pour obtenir le meilleur résultat de pose de produits rectifiés, il est conseillé de réaliser un joint de 2 mm. - Pour parfaire l'effet esthétique obtenu, Piemme conseille de confectionner des joints de la même couleur que les carreaux. - Vérifier avant la pose la compatibilité et convenance des remplissages pour joints avec le produit céramique. - Enlever les surplus des remplissages pour joints alors qu'ils sont encore frais. - Respecter scrupuleusement les instructions indiquées par les fabricants de remplissages pour joints. - Pour éliminer complètement tout résidu de pose pouvant gêner l'entretien courant et altérer les caractéristiques du produit, il est conseillé, à la fin de la pose, de procéder au nettoyage du carrelage avec des produits à base acide maximum 3% et de respecter les consignes du fabricant. Suivre impérativement les délais indiqués dans la notice car le contact trop prolongé de ces produits pourrait endommager la surface. - Pour éliminer facilement la présence éventuelle de cernes après la pose de carreaux rodés ou polis, utiliser un produit à base alcaline. - Pour ce qui est de la pose à l'extérieur, bien que les produits Piemme en grès cérame soient ingélifs, conformément aux normes européennes EN 14411/ISO 13006-ISO 10545.12, il convient cependant de respecter quelques règles fondamentales de manière à rendre le carrelage inattaquable au gel. Les conditions les plus importantes à remplir sont: le degré d'inclinaison, l'imperméabilisation, les joints de dilatation et l'utilisation de matériaux de pose appropriés. - Décorés réalisés avec des émaux et des métaux précieux Il est indispensable de protéger la surface pendant la pose. N'utiliser en aucun cas des produits abrasifs et/ou acides mais uniquement de l'eau et du savon neutre. Le fabricant ne répond pas des dommages éventuels de ces matériaux précieux causés par le frottement pendant la pose. Aucune réclamation, quelle qu'elle soit, concernant le matériau posé ne sera acceptée. 	<p>TYPE DE TACHE</p> <p>Bière - Vin - Glace - Café - Graisses végétales et animales - Encres Résidus de scotch - Huile de graissage - Hile de lin Crayon feutre Emaux - Teinture pour cheveux Caoutchouc pour pneus</p> <p>NETTOYAGE CONSEIL</p> <p>Détergents à base alcaline</p> <p>Cire de protection anti abrasion Dépôts de calcaire Tache de rouille</p> <p>Détergents à base d'acide</p> <p>Cire de bougie Résidus de scotch</p> <p>Solvant</p> <p>Pour d'ultérieures informations spécifiques consulter le département technique du site Piemme: www.ceramichepiemme.it</p>

Voci di capitolato

Specifications - Technische Beschreibung - Caractéristiques

GRES FINE PORCELLANATO AD IMPASTO COLORATO Superficie ceramica formata da un supporto compatto derivato da una miscela di pregiati minerali e decorato in superficie con smalti particolarmente resistenti. Resistente agli sbalzi termici, al gelo, all'attacco degli acidi e delle basi e tecnologicamente avanzato, trova impiego in condizioni di traffico medio pesanti. In base alle norme UNI EN 14411, viene classificato nel gruppo Bla ed è conforme ai requisiti della norma UNI EN 14411-G.	Assorbimento d'acqua	ISO 10545.3	≤ 0,5%
	Resistenza alla flessione	ISO 10545.4	≥ 35N/mm ²
	Resistenza all'attacco chimico	ISO 10545.13.14	Resistente
	Resistenza al gelo	ISO 10545.12	Resistente
	Resistenza agli sbalzi termici	ISO 10545.9	Resistente
	Resistenza dei colori alla luce	DIN 51094	Conforme
	Resistenza allo scivolamento	DIN 51130	R10 (nat) - R11 (strips/antislip)

COLOURED-BODY FINE PORCELAIN STONEWARE Ceramic surface consisting of a compact substrate made of a mix of precious materials and decorated on surface with particularly resistant glazes. Resistant against heat fluctuations, frost, acid and base attack, and technologically advanced, it is ideal for use in medium-heavy traffic situations. According to UNI EN 14411 standards, it is classified in the Bla group and complies with UNI EN 14411-G standard requirements.	Water absorption	ISO 10545.3	≤ 0,5%
	Bending strength	ISO 10545.4	≥ 35N/mm ²
	Resistance to chemical attack	ISO 10545.13.14	Resistant
	Frost resistance	ISO 10545.12	Resistant
	Thermal shock resistance	ISO 10545.9	Resistant
	Colours resistance to light	DIN 51094	In accordance
	Slippage resistance	DIN 51130	R10 (nat) - R11 (strips/antislip)

FEINSTEINZEUG AUS FARBIGER MASSE Keramikoberfläche mit einer kompakten Unterlegplatte aus einer Mischung hochwertiger Mineralstoffe und mit besonders beständigen Glasuren dekorierter Oberfläche. Beständig gegen Temperaturschocks, Frost, Säuren und Laugen sowie technologisch ausgereift für den Einsatz in mittlerem bis hohem Verkehr ausgesetzten Bereichen. Entspricht den Normen UNI EN 14411, zur Gruppe Bla gehörig und den Voraussetzungen der Norm UNI EN 14411-G konform.	Wasseraufnahme	ISO 10545.3	≤ 0,5%
	Biegezugfestigkeit	ISO 10545.4	≥ 35N/mm ²
	Beständigkeit gegen Chemikalien	ISO 10545.13.14	Widerstehend
	Frostbeständigkeit	ISO 10545.12	Widerstehend
	Temperaturwechselbeständigkeit	ISO 10545.9	Widerstehend
	Lichtbeständigkeit	DIN 51094	Erfüllt
	Rutschsicherheit	DIN 51130	R10 (nat) - R11 (strips/antislip)

GR»S C...RAME FIN ı P-TE COLOR...E Surface céramique formée d'un tesson compact issu d'un mélange de minéraux précieux; décor réalisé en surface avec des émaux particulièrement résistants. Résistance aux écarts thermiques, au gel, à l'attaque des acides et des bases. Matériau obtenu grâce à des technologies de pointe dont l'utilisation est indiquée en cas de passage moyennement intense. Aux termes des normes UNI EN 14411, ce matériau est classé dans le groupe Bla et il est conforme aux exigences de la norme UNI EN 14411-G.	Absorption d'eau	ISO 10545.3	≤ 0,5%
	Résistance à la flexion	ISO 10545.4	≥ 35N/mm ²
	Résistance à l'attaque chimique	ISO 10545.13.14	Résistant
	Résistance au gel	ISO 10545.12	Résistant
	Résistance aux écarts de température	ISO 10545.9	Résistant
	Résistance des couleurs à la lumière	DIN 51094	Conforme
	Résistance au glissement	DIN 51130	R10 (nat) - R11 (strips/antislip)

Aprile 2017



FSC® è una certificazione che consente al consumatore finale di riconoscere i prodotti fabbricati con materie prime che vengono da foreste gestite in modo responsabile anche dal punto di vista sociale.

FSC® is a certification that allows the consumer to identify products manufactured with raw materials from forests that are managed responsibly from the point of view of society.

CERAMICHE **PIEMME**
FLOOR AND MORE

INDUSTRIE CERAMICHE PIEMME S.P.A.

VIA DEL CROCIALE 42/44 - 41042 FIORANO (MO) - ITALY
TEL. +39 0536.849111 - FAX +39 0536.849402
WWW.CERAMICHEPIEMME.IT