

BLOCK2.0

KRONOS
CERAMICHE

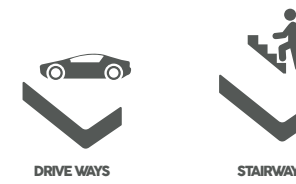

BLOCK2.0



DRIVE WAYS



STAIRWAY



INDUSTRY



URBAN LOCATIONS



HOSPITALITY AREAS



WALKWAYS



LANDSCAPING PROJECTS



GARDENS PATIO AREAS

INDEX

NAMUR

P.6

GENT

P.18

BRUGES

P.26

COTTO

P.34

SILVER WHITE

P.42

PORFIDO

P.52



BLOCK 2.0

MUCH MORE THAN BEAUTIFUL MUCH MORE THAN STRONG

La ricerca di Kronos guarda al passato e alla tradizione per presentare un nuovo prodotto estremamente resistente e duraturo, senza rinunciare alla componente estetica.

Con la consueta cura per il materiale e attenzione al dettaglio, Kronos ha realizzato Block 2.0 in 2 formati: 20,2x20,2 e 20,2x30,4 in 2 cm di spessore con bordo vintage.

I colori proposti sono 6 in 4 differenti materie: effetto pietra, ardesia, cotto e porfido.

Search for Kronos looks to the past and to tradition, to present a new product, extremely resistant and durable without sacrificing aesthetic component.

With the usual care for the material, and attention to detail, Kronos has made Block 2.0 in 2 sizes 8"x8" and 8"x12", 3/4" thick. The looks of the edges are Vintage effect.

La recherche de Kronos s'oriente vers le passé et vers la tradition afin de présenter un nouveau produit extrêmement résistant et durable, sans pour autant renoncer à la composante esthétique. Avec le soin habituel porté au matériau et l'attention constante prêtée au détail, Kronos a réalisé Block 2.0 dans 2 formats : 20,2x20,2 et 20,2x30,4 dans 2 cm d'épaisseur avec un bord vintage. Les couleurs proposées sont 6 et se déclinent dans 4 matières différentes : effet pierre, ardoise, terre cuite et porphyre.

Die Forschung von Kronos blickt auf die Vergangenheit und Tradition zurück, um ein extrem widerstandsfähiges und haltbares Produkt zu präsentieren, ohne die ästhetischen Aspekte außer Acht zu lassen. Mit der üblichen Sorgfalt für das Material und die Details hat Kronos Block 2.0 in 2 Formaten gefertigt: 20,2x20,2 und 20,2x30,4 in 2 cm Stärke mit Vintage-Rand.

Die angebotenen Farben sind 6 bei verschiedenen 4 Materialien: Stein-, Schiefer-, Cotto und Porphyroptik.



20,2x20,2 - 20,2x30,4

spessore: 2 cm

8"x8" - 8"x12"

thickness: ¾"

MUCH MORE THAN WINE

BLOCK 2.0



NAMUR
spessore: 2 cm
thickness: ¾"

BLOCK 2.0

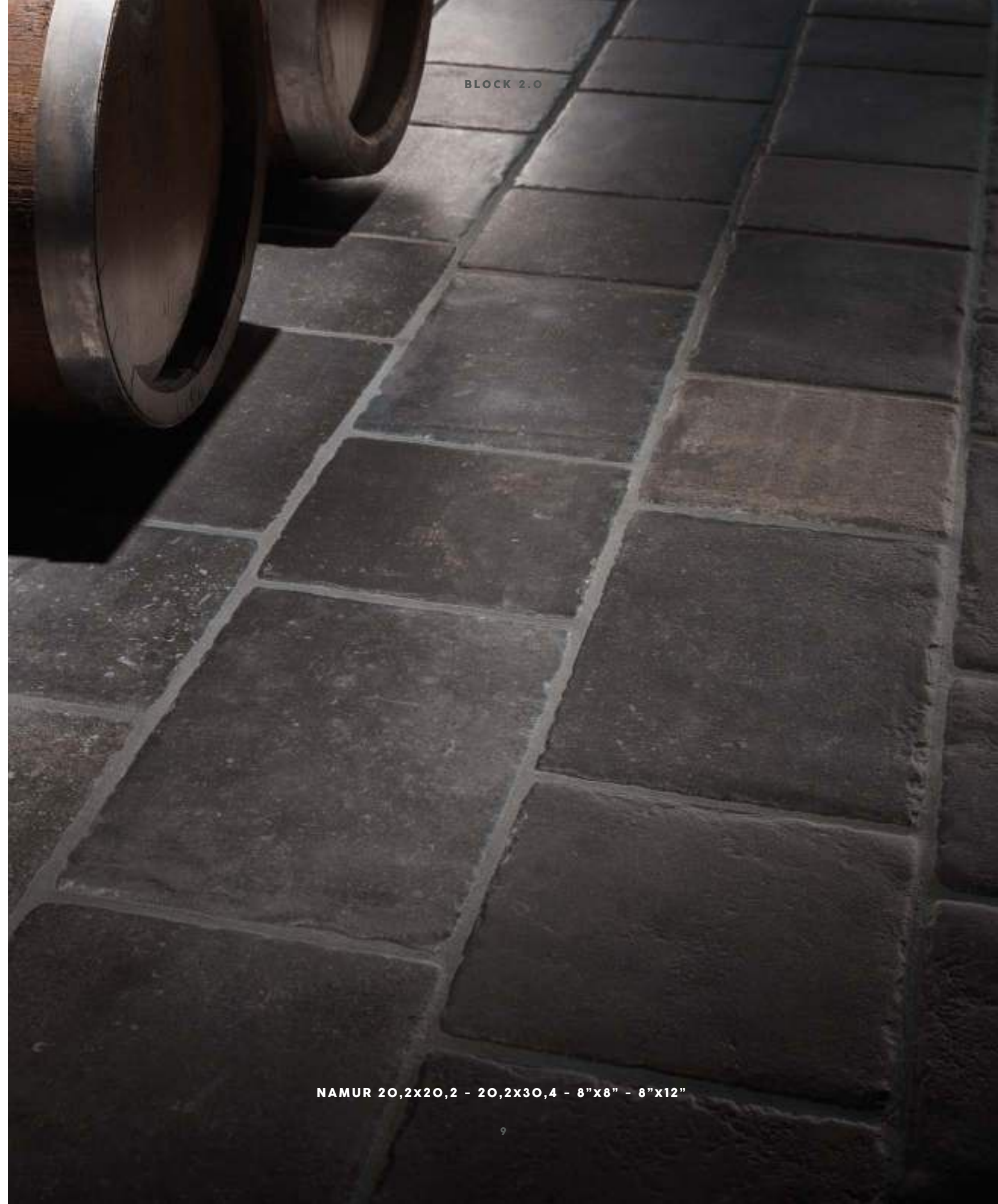

NAMUR 20,2x20,2 - 20,2x30,4 - 8"x8" - 8"x12"

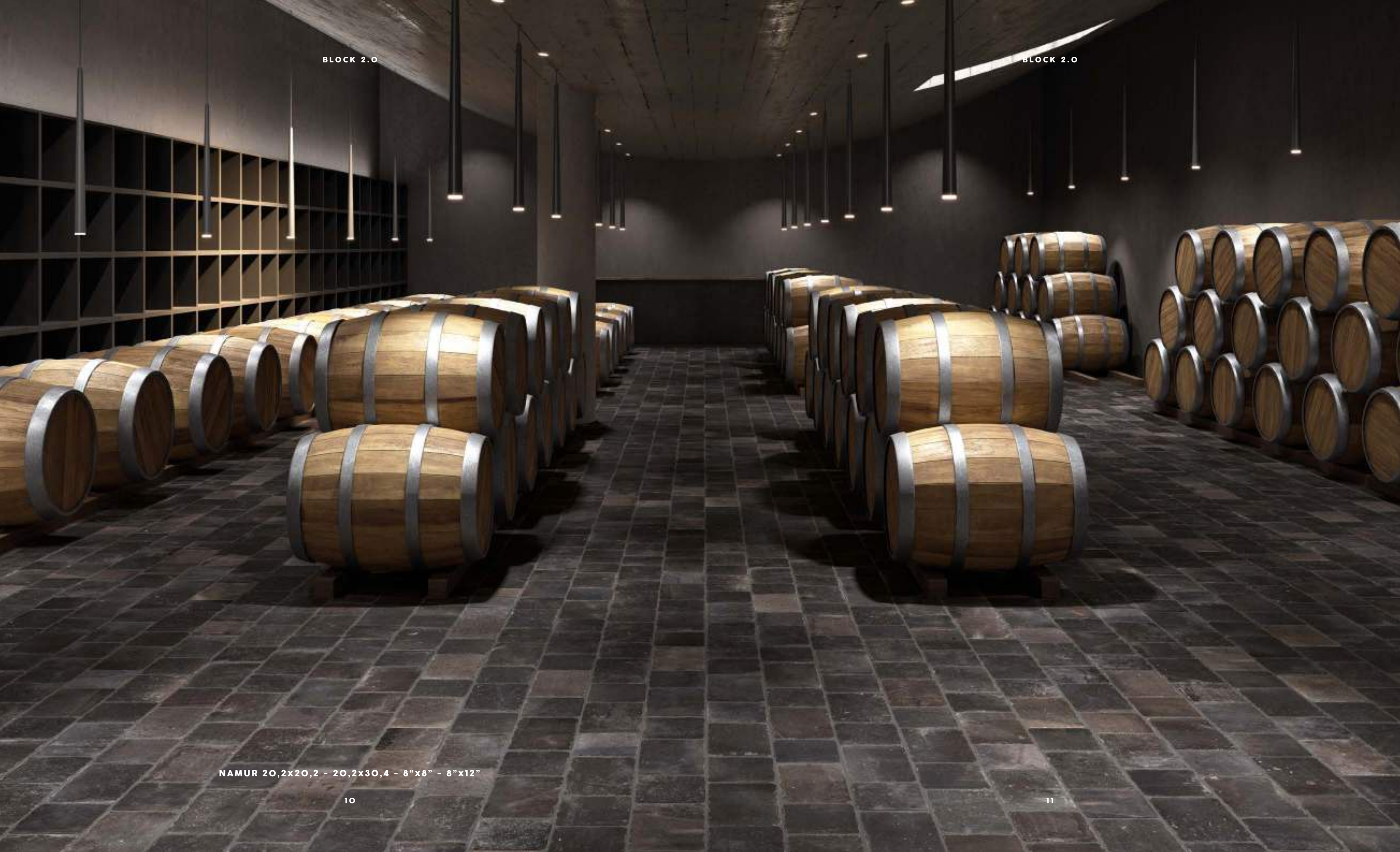

NAMUR 20,2x20,2 - 20,2x30,4 - 8"x8" - 8"x12"



BLOCK 2.0

NAMUR 20,2x20,2 - 20,2x30,4 - 8"x8" - 8"x12"



BLOCK 2.0

NAMUR
spessore: 2 cm
thickness: ¾"

BLOCK 2.0

PEZZI SPECIALI SU MISURA
SPECIAL PIECES MADE TO
MEASURE

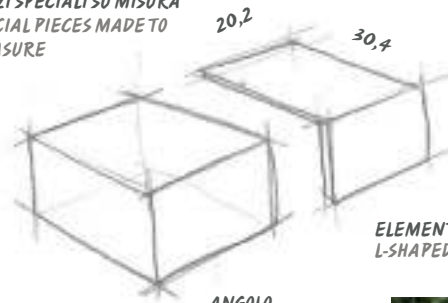

ALTEZZA SU MISURA,
IN QUESTO CASO
15 CM
HEIGHT MADE TO MEASURE,
IN THIS CASE 15 CM

ELEMENTO A ELLE
L-SHAPED ELEMENT

ANGOLO
CORNER



NAMUR
spessore: 2 cm
thickness: ¾"

BLOCK 2.0



NAMUR 20,2x20,2 - 20,2x30,4 - 8"x8" - 8"x12"
ELEMENTO A ELLE E ANGOLO SU MISURA - L-SHAPED ELEMENT AND CORNER MADE TO MEASURE

BLOCK 2.0

BLOCK 2.0



BLOCK 2.0

BLOCK 2.0

MUCH MORE THAN GARDEN

BLOCK 2.0



GENT
spessore: 2 cm
thickness: ¾"

BLOCK 2.0



GENT 20,2x20,2 - 20,2x30,4 - 8"x8" - 8"x12"



BLOCK 2.0



GENT
spessore: 2 cm
thickness: ¾"

BLOCK 2.0



GENT 20,2x20,2 - 20,2x30,4 - 8"x8" - 8"x12"



BLOCK 2.0

BLOCK 2.0

MUCH MORE THAN OUTDOOR

BLOCK 2.0



BRUGES
spessore: 2 cm
thickness: ¾"

BLOCK 2.0



BRUGES 20,2x20,2 - 20,2x30,4 - 8"x8" - 8"x12"



BRUGES 20,2X20,2 - 20,2X30,4 - 8"X8" - 8"X12"

BLOCK 2.0

BLOCK 2.0

MUCH MORE THAN OUTDOOR

BLOCK 2.0

BLOCK 2.0

SILVER WHITE 20,2x20,2 - 20,2x30,4 - 8"x8" - 8"x12"
COTTO 20,2x20,2 - 20,2x30,4 - 8"x8" - 8"x12"

BLOCK 2.0

BLOCK 2.0



COTTO 20,2x20,2 - 20,2x30,4 - 8"x8" - 8"x12"
ELEMENTO A ELLE E TORO SU MISURA - L-SHAPED ELEMENT AND BULLNOSE MADE TO MEASURE

DETTAGLIO COPRIMURO
WALL COVER DETAIL

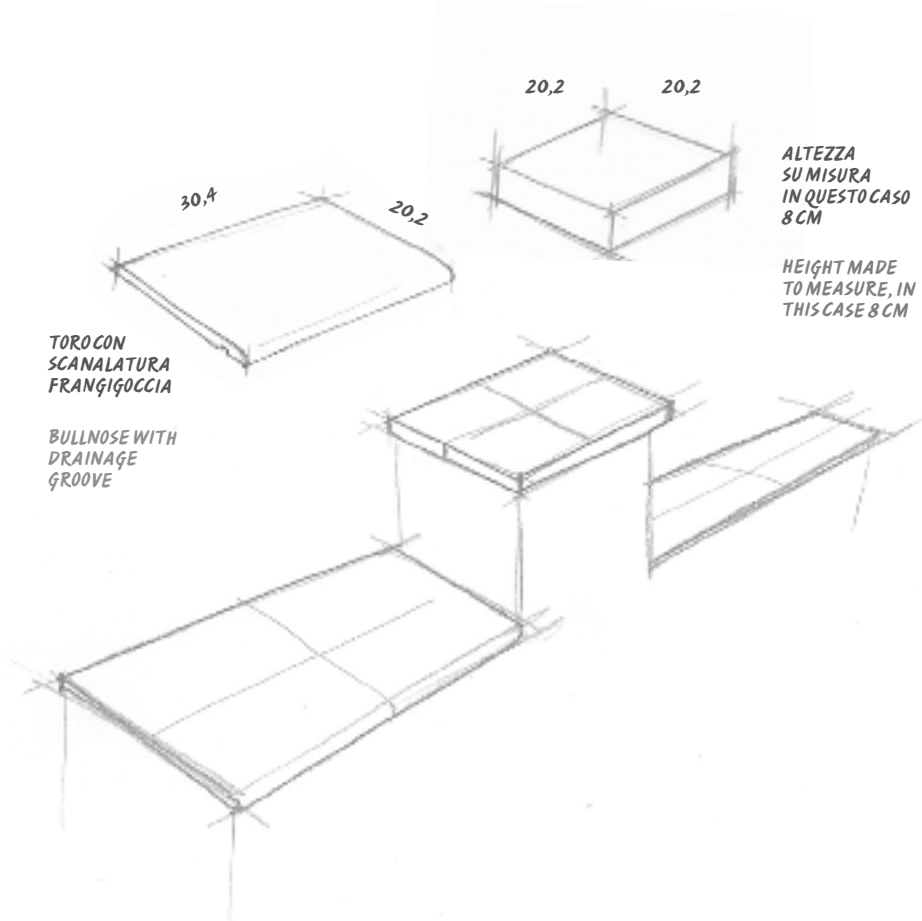

ALTEZZA SU MISURA IN QUESTO CASO 8 CM
HEIGHT MADE TO MEASURE, IN THIS CASE 8 CM

GRADINI
STEPS

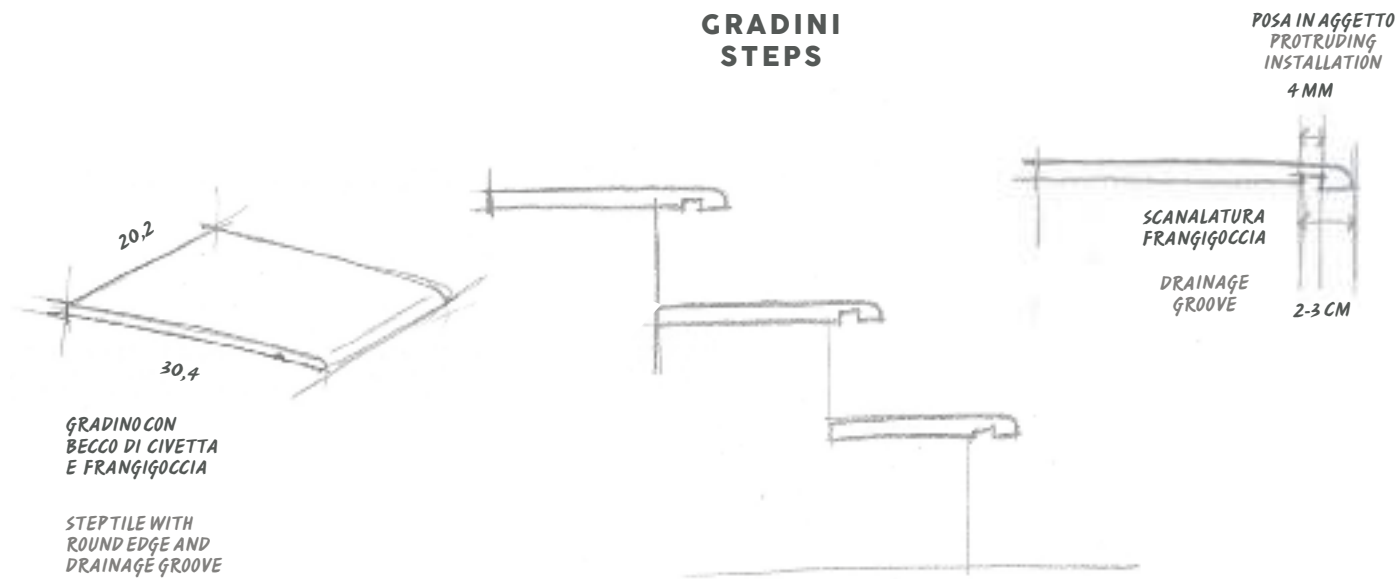

SCANALATURA FRANGIGOCCIA
DRAINAGE GROOVE 2-3 CM



COTTO 20,2x20,2 - 20,2x30,4 - 8"x8" - 8"x12"
GRADINO A BECCO DI CIVETTA CON SCANALATURA FRANGIGOCCIA, SU MISURA
STEPTILE WITH ROUND EDGE WITH DRAINGROOVE MADE TO MEASURE

BLOCK 2.0

BLOCK 2.0



COTTO 20,2x20,2 - 20,2x30,4 - 8"x8" - 8"x12"
ELEMENTO A ELLE E TORO SU MISURA - L-SHAPED ELEMENT AND BULLNOSE MADE TO MEASURE



BLOCK 2.0

BLOCK 2.0

MUCH MORE THAN OUTDOOR



BLOCK 2.0

BLOCK 2.0

STROBLHOF
ACTIVE FAMILY SPA RESORT

Stroblhof
Cafe Pizzeria

SILVER WHITE 20,2x20,2 - 20,2x30,4 - 8"x8" - 8"x12"
ELEMENTO A ELLE - L-SHAPED ELEMENT 10x60 - 4"x24"



BLOCK 2.0

SILVER WHITE 20,2x20,2 - 20,2x30,4 - 8"x12"
ELEMENTO A ELLE - L-SHAPED ELEMENT 4"x24"

BLOCK 2.0



SILVER WHITE
spessore: 2 cm
thickness: ¾"

BLOCK 2.0

BLOCK 2.0



SILVER WHITE 20,2x20,2 - 20,2x30,4 - 8"x8" - 8"x12"

BLOCK 2.0



SILVER WHITE
spessore: 2 cm
thickness: ¾"

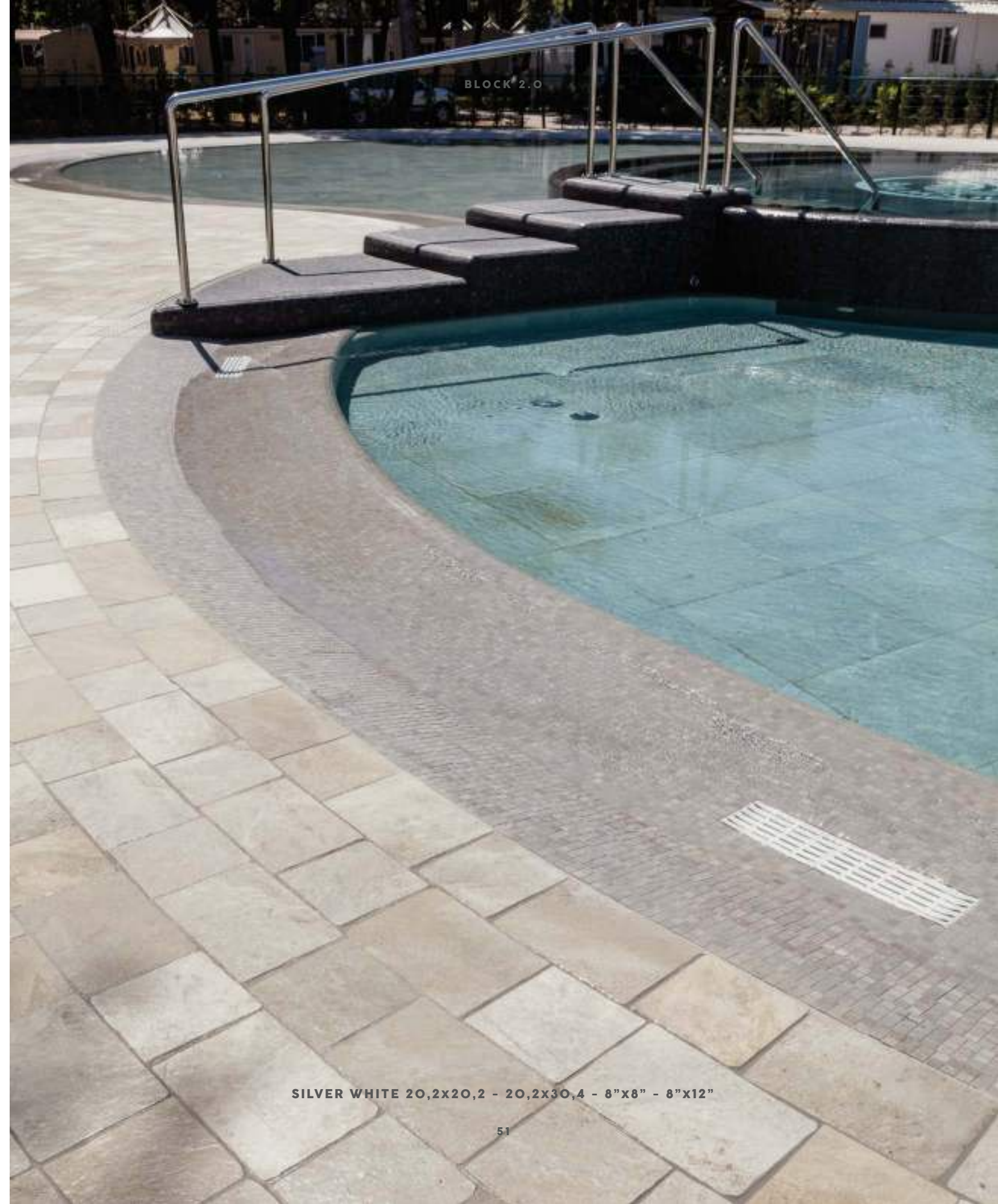

SILVER WHITE 20,2x20,2 - 20,2x30,4 - 8"x8" - 8"x12"

BLOCK 2.0

BLOCK 2.0

MUCH MORE THAN OUTDOOR

IL MEGLIO DELLA CUCINA ITALIANA

FRUTTA E VERDURA

Vegan

FRUTTA E VERDURA

SALUMI E INSACCATI

SALATI, AFFETTATI, SPICCATI

PORFIDO 20,2X20,2 - 20,2X30,4 - 8"X8" - 8"X12"

BLOCK 2.0



Lo spessore maggiorato di 20 mm e il piccolo formato permettono di aumentare la resistenza al rotolamento e contrastare i movimenti e le spinte create dalle ruote, rendendo il pavimento resistente e duraturo.

The 20 mm increased thickness and the small size makes it possible to increase rolling resistance and contrast the movements and thrust created by wheels, making the paving more resistant and longer lasting.

PORFIDO

spessore: 2 cm

thickness: ¾"

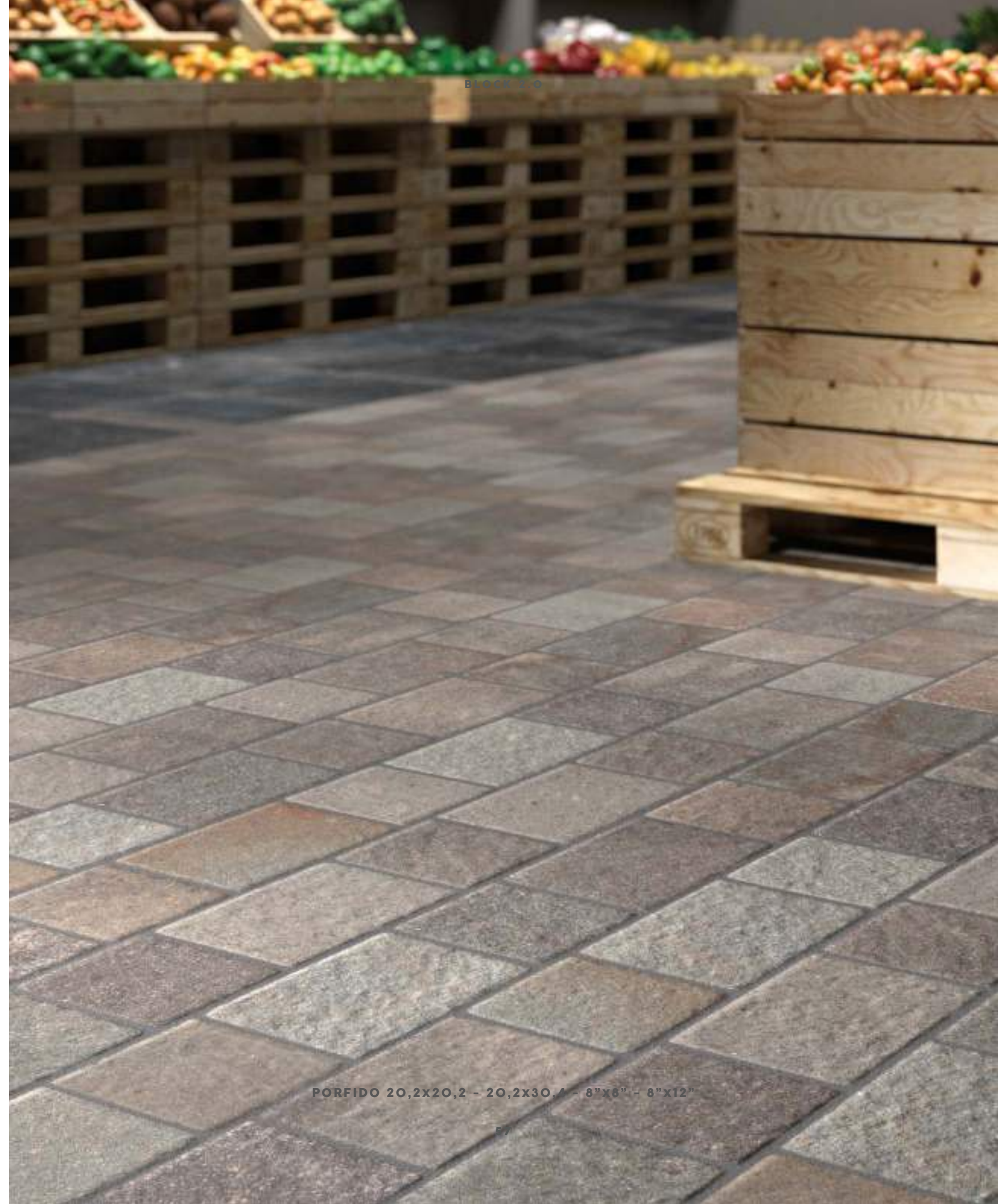

PORFIDO 20,2X20,2 - 20,2X30 A - 8"x6" - 8"x12"

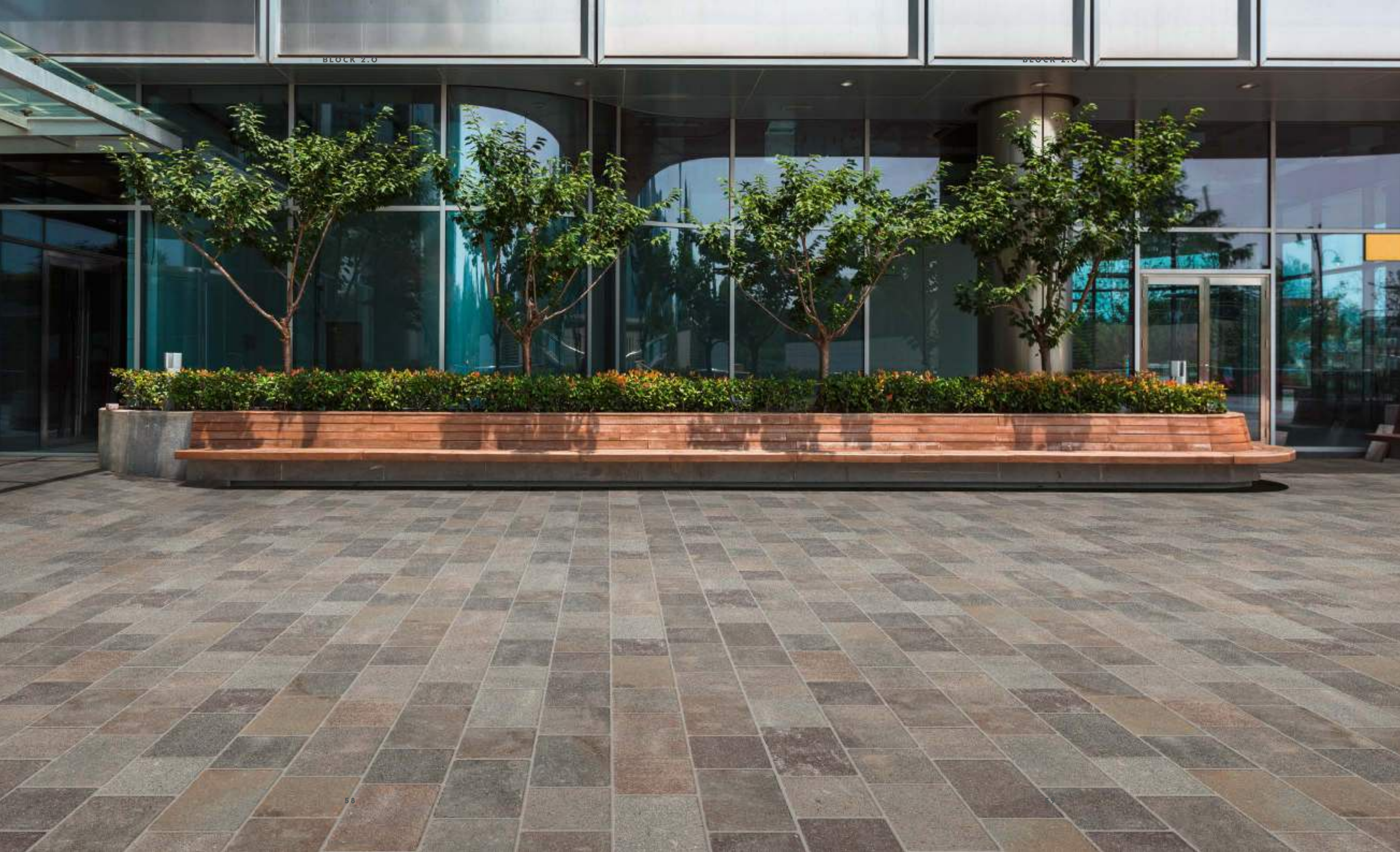

BLOCK 2.0

BLOCK 2.0



BLOCK2.0

FORMATI SIZES

20,2x20,2 - 20,2x30,4

8"x8" - 8"x12"

spessore: 2 cm

thickness: ¾"

COLORI COLORS

NAMUR - GENT - BRUGES - SILVER WHITE - COTTO - PORFIDO



DRIVE WAYS



STAIRWAY



INDUSTRY



URBAN
LOCATIONS



HOSPITALITY
AREAS



WALKWAYS



LANDSCAPING
PROJECTS



GARDENS
PATIO AREAS



BLOCK 2.0



 **20mm - 3/4"**

 20,2x20,2 NAMUR 2.0
 9500 ■ K0694

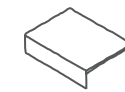

 20,2x30,4 NAMUR 2.0
 9505 ■ K0694

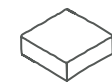

20,2x30,4 NAMUR ELLE
 9523 ■ K0215

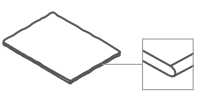

20,2x20,2 NAMUR ANG.
 9539 ■ K0420



20,2x30,4 NAMUR TORO
 9533 ■ K0212

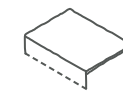

PEZZI SPECIALI REALIZZATI SU MISURA - SPECIAL PIECES MADE TO MEASURE

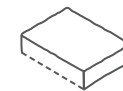



GENT

BLOCK 2.0



 20mm - 3/4"

20,2x20,2 GENT 2.0
9501 ■ K0694

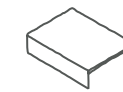

20,2x30,4 GENT 2.0
9506 ■ K0694

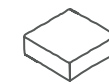

20,2x30,4 GENT ELLE
9524 ■ K0215

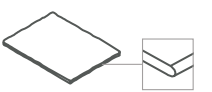

20,2x20,2 GENT ANG.
9540 ■ K0420



20,2x30,4 GENT TORO
9534 ■ K0212

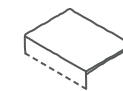

PEZZI SPECIALI REALIZZATI SU MISURA - SPECIAL PIECES MADE TO MEASURE

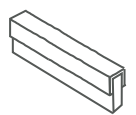
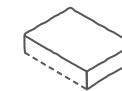





BRUGES

BLOCK 2.0



 20mm - 3/4"

20,2x20,2 BRUGES 2.0
9502 ■ K0694

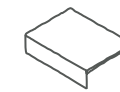

20,2x30,4 BRUGES 2.0
9507 ■ K0694

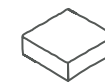

20,2x30,4 BRUGES ELLE
9525 ■ K0215

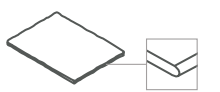

20,2x20,2 BRUGES ANG.
9541 ■ K0420



20,2x30,4 BRUGES TORO
9535 ■ K0212

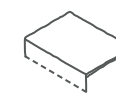

PEZZI SPECIALI REALIZZATI SU MISURA - SPECIAL PIECES MADE TO MEASURE

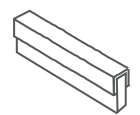
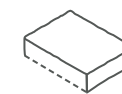





COTTO

BLOCK 2.0



 **20mm - 3/4"**

20,2x20,2 COTTO 2.0
9503 ■ K0694

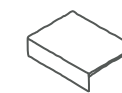

20,2x30,4 COTTO 2.0
9508 ■ K0694

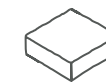

20,2x30,4 COTTO ELLE
9521 ■ K0215

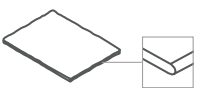

20,2x20,2 COTTO ANG.
9537 ■ K0420



20,2x30,4 COTTO TORO
9531 ■ K0212

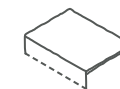

PEZZI SPECIALI REALIZZATI SU MISURA - SPECIAL PIECES MADE TO MEASURE

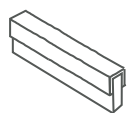
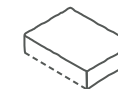





SILVER WHITE

BLOCK 2.0



 20mm - 3/4"

20,2x20,2 S. WHITE 2.0
9504 ■ K0694



20,2x30,4 S. WHITE 2.0
9509 ■ K0694



20,2x30,4 S. WHITE ELLE
9520 ■ K0215

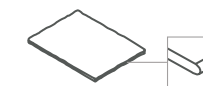

20,2x20,2 S. WHITE ANG.
9536 ■ K0420



20,2x30,4 S. WHITE TORO
9530 ■ K0212

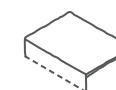

PEZZI SPECIALI REALIZZATI SU MISURA - SPECIAL PIECES MADE TO MEASURE

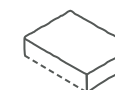



PORFIDO

BLOCK 2.0



 **20mm - 3/4"**

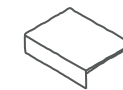

20,2x30,4 PORFIDO ELLE
9522 ■ K0215

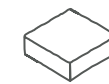

20,2x20,2 PORFIDO ANG.
9538 ■ K0420



20,2x30,4 PORFIDO TORO
9532 ■ K0212



20,2x20,2 PORFIDO 2.0
9510 ■ K0694



20,2x30,4 PORFIDO 2.0
9515 ■ K0694

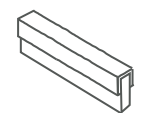
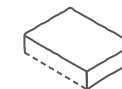
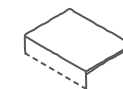

PEZZI SPECIALI REALIZZATI SU MISURA - SPECIAL PIECES MADE TO MEASURE

SCHEMI DI POSA PER PAVIMENTAZIONI ESTERNE, CARRABILI E PEDONALI
LAYING SCHEMES FOR OUTDOOR PAVING FOR VEHICLES AND PEDESTRIANS

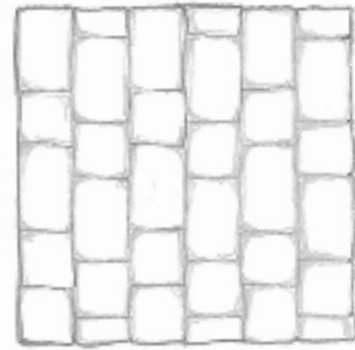

1
20,2x30,4 - 60%
20,2x20,2 - 40%

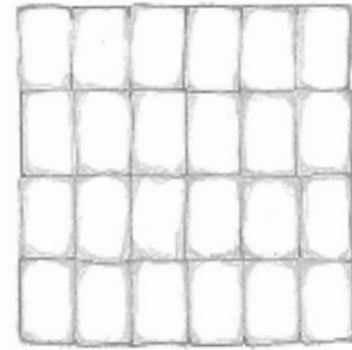

2
20,2x30,4

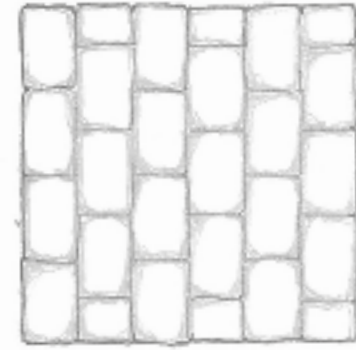

3
20,2x30,4

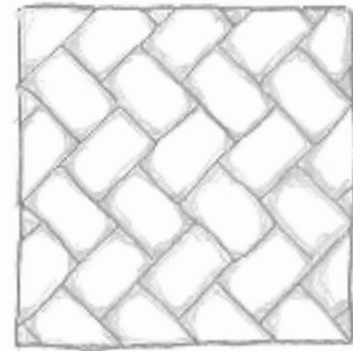

4
20,2x30,4

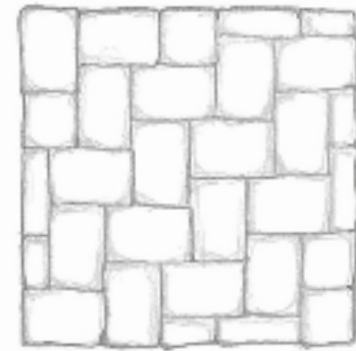

5
20,2x30,4

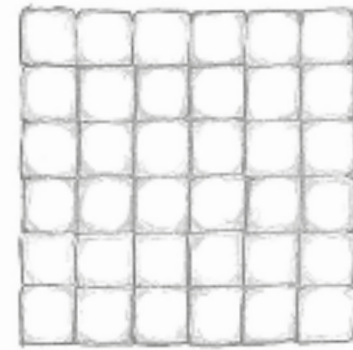

6
20,2x20,2

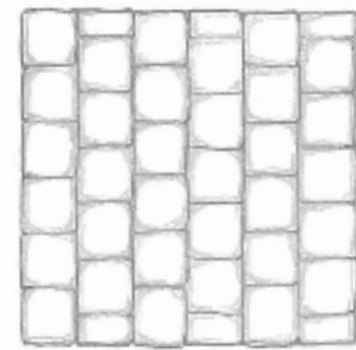

7
20,2x20,2

GRADINI
STEPS

SCALA REALIZZATA CON
PEZZO SPECIALE AD ELLE
E ANGOLO

STAIRS CREATED WITH
L-SHAPED SPECIAL PIECE
AND CORNER

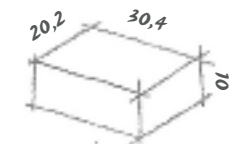
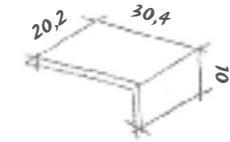
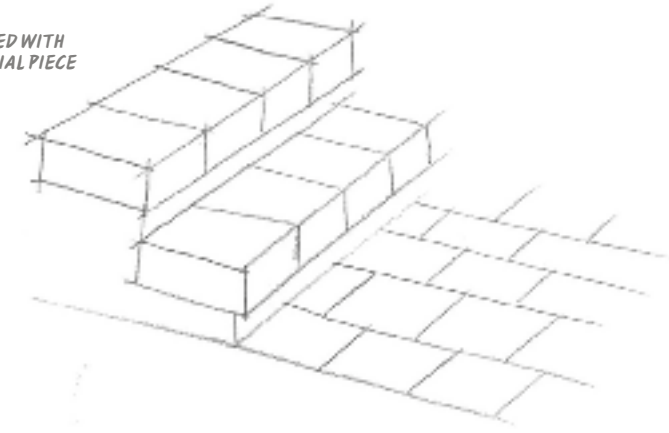

SCALA REALIZZATA
CON SEMPLICE
FONDO 20,2x30,4

STAIRS CREATED WITH
SIMPLE 20,2x30,4 BASE
TILE

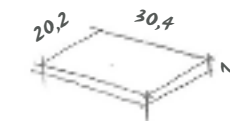
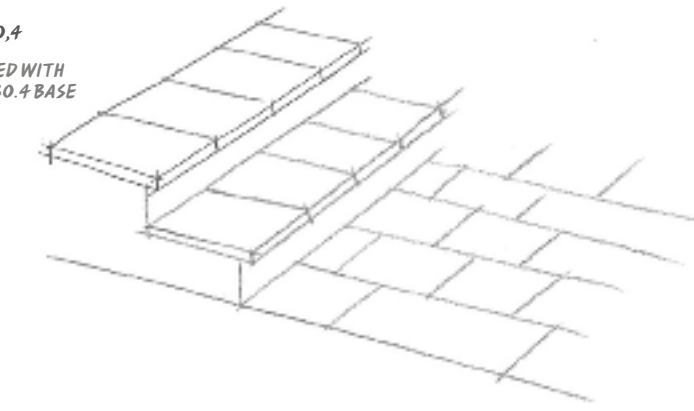

POSSIBILI FINITURE:
POSSIBLE FINISHES:



CON PIASTRELLA SINGOLA
WITH SINGLE TILE



CON RIPRESA DELLA COSTA
FINISHED EDGE

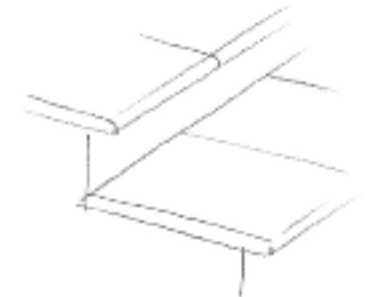

LAVORAZIONE A BECCO DI CIVETTA
BULLNOSE MACHINING



OGNI TIPO DI SCALINO
PUÒ ESSERE REALIZZATO
CON SCANALATURA
FRANGIGOCCIA
ALL TYPES OF STEPS CAN BE
MADE WITH A DRAINAGE
GROOVE

BLOCK 2.0

**POSE VIALETTI
WALKWAYS LAYING**

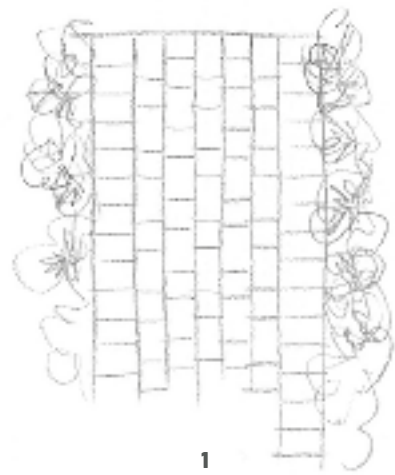

1
20,2x20,2
20,2x30,4

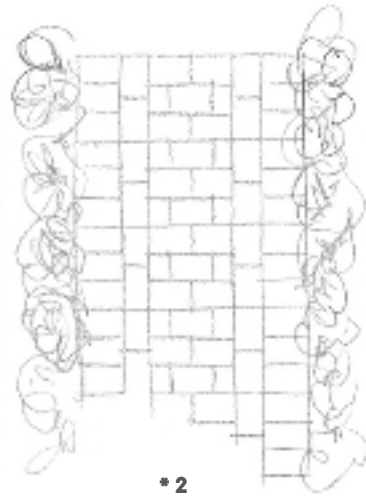

***2**
20,2x30,4

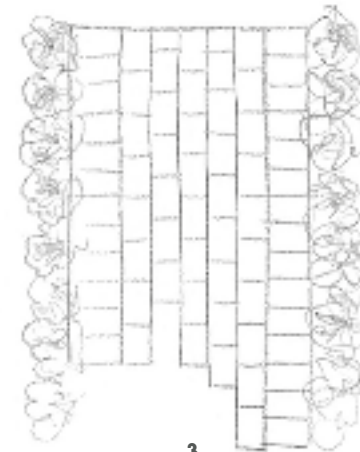

3
20,2x30,4

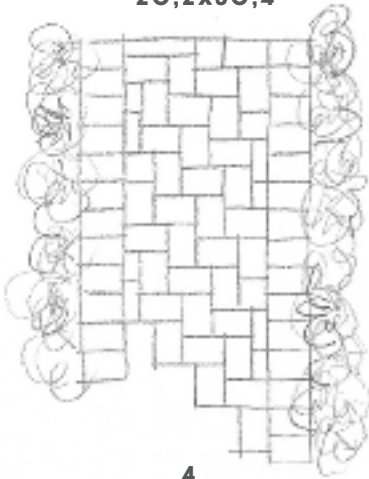

4
20,2x30,4



***5**
20,2x30,4

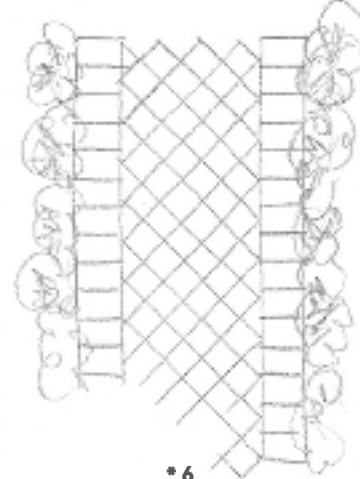

***6**
20,2x20,2
20,2x30,4



***7**
20,2x30,4

Il piccolo formato agevola la creazione di curve.
The small size makes it easier to create curves.

*La posa contraria al senso di marcia, aumenta la portata al carico.
*Laying the tiles in the opposite direction to traffic increases the load-bearing capacity.

BLOCK 2.0

**BORDURA
EDGE**

Block permette di creare bordure per delimitare vialetti.
La bordura è un elemento molto importante perché funge da controllo strutturale ed impedisce al vialetto di espandersi sotto il proprio peso.

Block makes it possible to create edges to delimit paths and driveways.
These edges are very important because they offer structural control and prevent the driveway from expanding under its own weight.

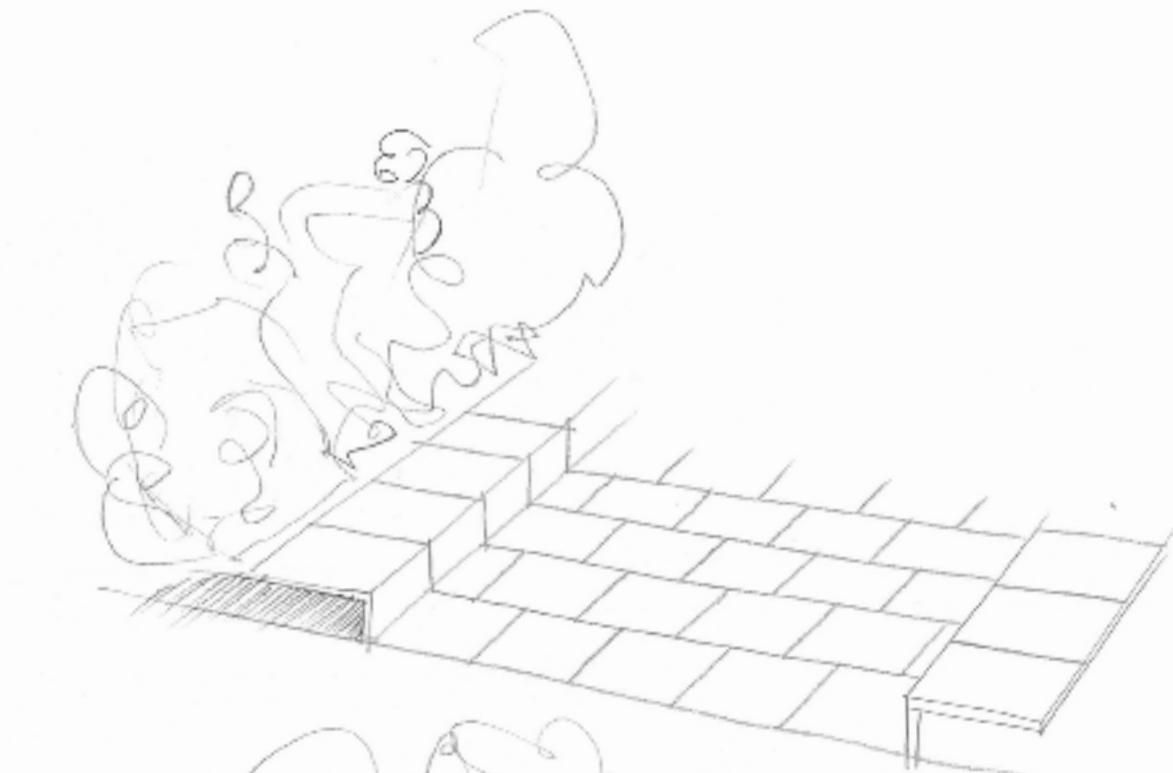

**ELEMENTO A ELLE
L-SHAPED ELEMENT**

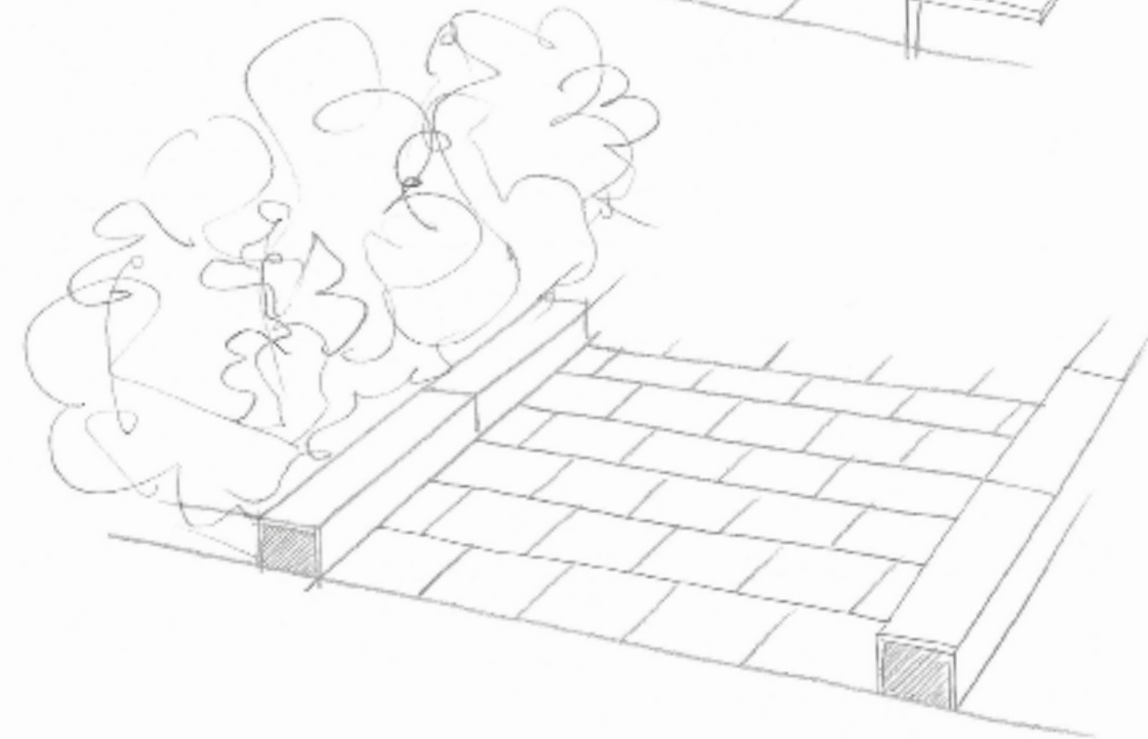
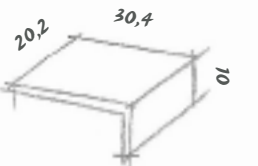

**CORDOLO
REALIZZATO
SU MISURA
CURB MADE TO
MEASURE**

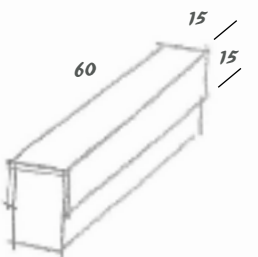

IMBALLI_PACKAGING_EMBALLAGES_VERPACKUNGEN

BLOCK2.0	Thickness	Pezzi per scatola	M ² per scatola	Kg per scatola	Scatole per pallet	M ² per pallet	KG per pallet
20,2x20,2 - 8"x8"	20 mm - ¾"	12	0,49	20,40	54	26,46	1121,6
20x30 - 8"x12"	20 mm - ¾"	7	0,43	20,40	60	25,80	1244

CARATTERISTICHE TECNICHE_TECHNICAL CHARACTERISTICS_CARACTÉRISTIQUES TECHNIQUES_TECHNISCHE DATEN

NORME STANDARDS NORMES NORMEN	CARATTERISTICHE E PROPRIETÀ CHARACTERISTICS OR PROPERTIES CARACTÉRISTIQUES OU PROPRIÉTÉS EIGENSCHAFTEN UND GÜTEMERKMALE	SECONDO LE NORME COMPLIANCE WITH STANDARDS CONFORME AUX NORMES ENTSPRECHEND DEN NORMEN UNI EN 14411 G	
ISO 10545-2	Spessore - Thickness Épaisseur - Stärke	20 mm - ¾"	Conforme alle norme - Complies with standard Conforme aux normes - Normgerecht
	Lunghezza e larghezza - Length and width Longueur et largeur - Länge und Breite	+/- 0,5 %	Conforme alle norme - Complies with standard Conforme aux normes - Normgerecht
ISO 10545-3	Assorbimento d' acqua - Water absorption Absorption d'eau - Wasseraufnahme	E < = 0,04 %	Conforme alle norme - Complies with standard Conforme aux normes - Normgerecht
ISO 10545-4	Resistenza alla flessione - Bending strength Résistance à la flexion - Biegezugfestigkeit	-	53 N/mm²
ISO 10545-6	Resistenza all'abrasione - Resistance to deep abrasion Résistance à l'abrasion profonde - Tiefenabrieb	<128 mm³	Conforme alle norme - Complies with standard Conforme aux normes - Normgerecht
ISO 10545-9	Resistenza agli sbalzi termici - Thermal shock resistance Résistance aux écarts thermiques - Temperaturwechselbeständigkeit	Richiesta - Requested Demandée - Auf Anfrage	Conforme alle norme - Complies with standard Conforme aux normes - Normgerecht
ISO 10545-12	Resistenza al gelo - Frost resistance Résistance au gel - Frostbeständigkeit	Richiesta - Requested Demandée - Auf Anfrage	Conforme alle norme - Complies with standard Conforme aux normes - Normgerecht
ISO 10545-13	Resistenza agli agenti chimici - Chemical resistance Résistance à l'attaque chimique - Beständigkeit gegen Chemikalien	-	UA ULA UHA
ISO 10545-14	Resistenza alle macchie - Resistance to stain Résistance aux taches - Fleckenfestigkeit	-	5
EN 13501 - 1	Resistenza al fuoco - Fire resistance Résistance au feu - Feuerwiderstand	-	Classe A1 - A1 FL
DIN 51130	Resistenza allo scivolamento - Slip resistance Résistance au glissement - Bestimmung der rutschhemmende eigenschaft	-	R11 grip
DIN 51097	Resistenza allo scivolamento - Slip resistance Résistance au glissement - Bestimmung der rutschhemmende eigenschaft	-	C grip
B.C.R.A. C.A. B.C.R.A. G.B. D.M. 236 del 4.6.1989	Resistenza allo scivolamento - Slip resistance Résistance au glissement - Bestimmung der rutschhemmende eigenschaft	Tortus Test	66 DRY / 60 WET
ANSI A137.1 BOT 3000	Resistenza allo scivolamento - Slip resistance Résistance au glissement - Bestimmung der rutschhemmende eigenschaft	-	Wet 0,70
B-ANSI 118.6.2013	Resistenza alla compressione - Compression resistance Résistance à la compression - Druckfestigkeit	-	MpA 202
CAHIERS CSTB 3778 annexe 6	Resistenza allo schock lordo - Heavy shock resistance Résistance au choc lourd - Beständigkeit gegenüber schweren Stößen	-	Classe 1
CAHIERS CSTB 3778 annexe 5	Determinazione al rotolamento pesante - Heavy rolling test Détermination de la résistance au roulement lourd - Bestimmung der Beständigkeit gegenüber schwerem Rollen	-	Non si sono riscontrate tracce di abrasioni e/o rotture né superficiali né massive. At the end of the test, no surface or massive abrasions and/or breakages were found. À la fin du test, aucune trace d'abrasions et/ou de ruptures, superficielles ou massives, n'a été constatée. Am Ende der Prüfung wurden weder oberflächlich noch in der Tiefe Spuren von Abrieb und/oder Brüchen festgestellt.
ASTM C 1028/07	Resistenza allo scivolamento - Slip resistance Résistance au glissement - Bestimmung der rutschhemmende eigenschaft	-	0,76 DRY / 0,62 WET
ENV 12633 BPN	Pendolum	-	GRIP: Pendolum con pattino 4S: 68 DRY / 60 WET Pendolum con pattino TRL: 87 DRY / 52 WET
DIN 51094	Stabilità dei colori alla luce e ai raggi U.V. Colour stability on exposure to light and UV rays Stabilité des couleurs à la lumière et aux rayons U.V. Farblichkeit unter Lichteinluss und UV-Strahlung	-	Conforme alle norme, no variazioni Complies with standard, no variation Conforme aux normes, pas de changements Normgerecht, keine Aenderung



Kronos 2 ceramiche S.p.A.

Sede legale: Strada delle Fornaci, 20 41126 Modena Italy
Sede amministrativa: Via Giardini, 62 41042 Fiorano Modenese (Mo) Italy
tel. +39 0536 927711 - info@kronosceramiche.com
www.kronosceramiche.com

