

# PURITY OF MARBLE



CERAMICHE  
SUPERGRES



CERAMICHE  
SUPERGRES

PURITY OF MARBLE

# PURITY OF MARBLE

## La purezza e l'eleganza del marmo.

La nobiltà del marmo e la raffinatezza delle venature cromatiche trovano un perfetto punto d'incontro in Purity of Marble. Un progetto completo di pavimenti in gres porcellanato e di rivestimenti in pasta bianca che interpreta in chiave ceramica l'eleganza e la bellezza di sei marmi pregiati - Statuario, Lasa, Calacatta, Imperial Grey, Marfil e Royal Beige - offrendo all'architettura contemporanea soluzioni di design senza tempo.

### *The purity and elegance of marble*

*The nobility of marble and the elegance of coloured vein markings find a perfect fit in the Purity of Marble. A complete project of floors in porcelain stoneware and walls in white-paste tiles that ceramically interprets the elegance and beauty of six precious marbles - Statuario, Lasa, Calacatta, Imperial Grey, Marfil and Royal Beige - offering timeless design solutions to contemporary architecture.*

### *La pureté et l'élégance du marbre.*

*La noblesse du marbre et la finesse des veinures colorées se rencontrent avec bonheur dans Purity of Marble. Un projet de revêtements de sols en grès cérame et de revêtements muraux en pâte blanche, qui, par le biais de la céramique, interprète l'élégance et la beauté de six marbres de grande valeur portant les noms de Statuario, Lasa, Calacatta, Imperial Grey, Marfil et Royal Beige, et qui mettent à la disposition de l'architecture contemporaine des solutions design intemporelles.*

### *Die Reinheit und Eleganz von Marmor.*

*Edler Marmor und elegante farbige Äderungen treffen bei Purity of Marble perfekt aufeinander. Ein komplettes Sortiment von Bodenbelägen aus Feinsteinzeug und weißscherbigen Wandfliesen lässt die Eleganz und Schönheit von sechs edlen Marmorarten - Lasa, Calacatta, Imperial Grey, Marfil und Royal Beige - als Feinsteinzeug wieder entstehen. Zeitlose Gestaltungslösungen für die moderne Architektur.*

### *La pureza y elegancia del mármol.*

*La nobleza del mármol y la refinación de los veteados cromáticos encuentran un punto de confluencia perfecto en Purity of Marble. Un proyecto completo de pavimentos de gres porcelánico y de revestimientos de pasta blanca que interpreta en clave cerámica la elegancia y la belleza de seis mármoles - Statuario, Lasa, Calacatta, Imperial Grey, Marfil y Royal Beige - ofreciendo a la arquitectura contemporánea soluciones de diseño atemporales.*

### *Чистота и элегантность мрамора.*

*Свойства благородного мрамора и изящные цветные прожилки нашли отражение в безукоризненном стиле коллекции Purity of Marble. Комплексный проект напольных покрытий из керамического гранита и облицовочных покрытий из белой массы воссоздает с помощью керамики красоту и элегантность мрамора шести видов - Statuario, Lasa, Calacatta, Imperial Grey, Marfil и Royal Beige, позволяя современной архитектуре находить неустаревающие со временем дизайнерские решения.*





Scolpire non è scavare una pietra,  
è trovare il respiro della vita in essa e rivelarlo.

Sulle superfici di Purity of Marble rivive tutto il fascino  
dei marmi più pregiati, unici nella loro bellezza.  
Delicate venature, profondi dettagli cromatici e nobili sfumature  
rivelano l'essenza più intima della materia e arredano gli spazi,  
conferendogli eleganza e luminosità.

Sculpting is not carving stone, it is finding the breath of life  
in it and revealing it.

All the charm and unique beauty of the most precious marbles are brought to life in the Purity of Marble  
surfaces. Delicate vein markings, intense chromatic details and noble nuances reveal the most intimate  
essence of the material and decorate the spaces, creating a sense of elegance and luminosity.

Sculpter une pierre sans la creuser, c'est y trouver  
le souffle de la vie et le révéler.

Sur les surfaces de Purity of Marble, c'est tout le charme des marbres les plus inestimables et les  
plus beaux qui revit. De frêles veinures, de profonds détails chromatiques et de nobles nuances  
révèlent l'essence la plus intime de la matière et revêt les espaces d'élégance et de lumière.

Der Bildhauer meißelt nicht in Stein, sondern findet das Leben darin und  
lässt es wieder ans Licht treten.

Die Fliesen der Kollektion Purity of Marble bringen die ganze Faszination von edlem Marmor von  
einzigartiger Schönheit zum Ausdruck. Zarte Äderungen, tiefe farbige Details und edle Nuancen  
lassen den intimsten und wesentlichsten Charakter dieser Fliesen hervortreten und gestalten die  
Räume, verleihen ihnen Eleganz und freundliche Helligkeit.

Esculpir no es excavar una piedra, es encontrar el soplo  
de la vida en ella y revelarlo.

En las superficies de Purity of Marble revive el encanto de los mejores mármoles, únicos por su  
belleza. Delicados veteados, profundos detalles cromáticos y nobles matices revelan la esencia  
más íntima de la materia y decoran los espacios, otorgándoles elegancia y luminosidad.

Ваять не означает долбить камень, это умение вдохнуть в него жизнь и  
показать естественную природу материала.

На поверхностях плитки из коллекции Purity of Marble проявляется совершенство наиболее  
ценных и уникальных по своей красоте разновидностей мрамора. Нежные прожилки,  
глубокие детали цветовой палитры и благородные оттенки подчеркивают внутреннюю  
сущность материи, способной придавать пространствам элегантность и великолепие.



ROYAL BEIGE 6 - 17



CALACATTA 18 - 29

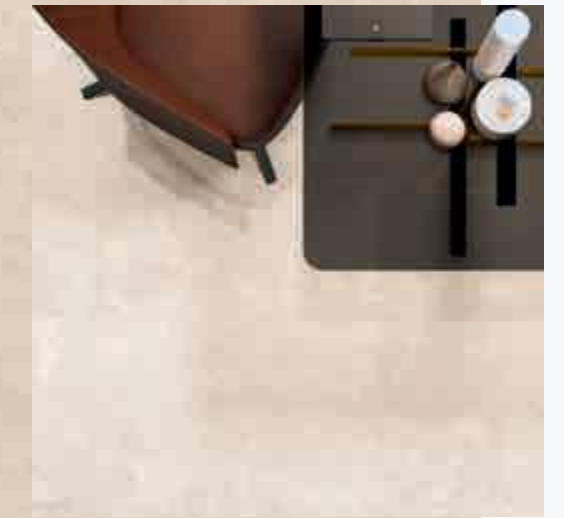

MARFIL 30 - 43

LASA 44 - 49



STATUARIO 50 - 55



IMPERIAL GREY 56 - 65





# ROYAL BEIGE



Avolgente e intimo, Royal Beige custodisce il fascino di uno stile impeccabile. Delicate sfumature si alternano a venature più decise, donando agli ambienti una perfezione estetica intramontabile, insensibile alle mode del tempo.

Enveloping and intimate, Royal Beige preserves the charm of an impeccable style. Delicate nuances alternate with bolder veining effects to give the environments a timeless look that never goes out of style.

Caressante et intime, Royal Beige garde le charme d'un style impeccable. De délicates nuances s'alternent à des veinures plus marquées, donnant aux espaces une impérissable perfection esthétique, indifférente aux modes.

Royal Beige lässt mit dem Charme seines vollendeten Stils ein gemütliches und intimes Ambiente entstehen. Zarte Farbtöne wechseln mit markanten Äderungen ab und verleihen den Räumen eine zeitlose Ästhetik, der die Moden der Zeit nichts anhaben können.

Envolvente e intimo, Royal Beige custodia el encanto de un estilo impecable. Matices delicados se alternan a veteados decididos y regalan a los espacios una perfección estética eterna, que se desentiende de las modas.

Уютная и обволакивающая атмосфера интерьера, создаваемого с помощью мрамора Royal Beige, хранит пленительные черты безукоризненного стиля. Чередование нежных оттенков с более яркими прожилками наделяет помещения непреходящим эстетическим совершенством, нечувствительным к капризным изменениям моды.







## ROYAL BEIGE

FLOOR  
PURITY royal beige lux 120x120 RT - 48"x48"

WALL  
PURITY royal beige 3D line 32x45 RT . 12,6"x18"  
PURITY royal beige lux 120x120 RT - 48"x48"



## ROYAL BEIGE

FLOOR  
PURITY royal beige lux 120x120 RT - 48"x48"

WALL  
PURITY royal beige 3D line 32x45 RT . 12,6"x18"



FLOOR  
PURITY royal beige lux 120x120 RT - 48"x48"



## ROYAL BEIGE

FLOOR  
PURITY calacatta lux 75x75 RT - 30"x30"

WALL  
PURITY royal beige 30,5x91,5 RT - 12"x36"  
PURITY royal beige struttura fluid 30,5x91,5 RT - 12"x36"





## ROYAL BEIGE

WALL  
PURITY royal beige 30,5x91,5 RT . 12"x36"



WALL  
PURITY royal beige campitura ramage 30,5x91,5 RT . 12"x36"





# CALACATTA



La migliore selezione di Calacatta, caratterizzata da inconfondibili venature e dettagliate sfumature di colore, crea ambienti esclusivi, contraddistinti da un'eleganza senza tempo.

The best selection of Calacatta, characterized by deep veining and detailed color hues, creates exclusive ambiances, marked by a timeless elegance.

La meilleure sélection de Calacatta, caractérisée par des veines incomparables et des nuances de couleur détaillées, crée des espaces exclusifs, caractérisés par une élégance intemporelle.

Die beste Auswahl an Calacatta, charakterisiert durch unverkennbare Aderungen und detaillierte Farbverläufe, schafft exklusive Ambiente, die sich durch zeitlose Eleganz auszeichnen.

La mejor selección de Calacatta, caracterizada por inconfundibles venas y detallados matices de color, crea ambientes exclusivos, distinguidos por una elegancia intemporal.

Элитная фактура мрамора Calacatta с ее выразительными прожилками и роскошными цветовыми оттенками позволяет вдохнуть в интерьер вневременную элегантность.







## CALACATTA

FLOOR  
PURITY calacatta lux 75x150 RT . 30°x60°

WALL  
PURITY calacatta lux 75x150 RT . 30°x60°  
profilo metallo oro 0,5x100 . 0,2°x40°





## CALACATTA

WALL  
PURITY calacatta lux 75x150 RT . 30"x60"



FLOOR  
PURITY calacatta lux 75x150 RT . 30"x60"





## CALACATTA

WALL  
PURITY calacatta 30,5x91,5 RT . 12"x36"  
PURITY calacatta strutt. fluid 30,5x91 RT . 12"x36"

FLOOR  
ART tobacco 75x150 RT . 30"x60" serie ART





## CALACATTA

FLOOR  
PURITY calacatta lux 120x120 RT . 48"x48"



FLOOR & WALL  
PURITY calacatta lux 120x120 RT . 48"x48"



# MARFIL



Declinata nelle calde tonalità del Marfil, la purezza ispirativa del marmo trasferisce agli ambienti armonia e naturalezza, rivestendo con eleganti sfumature gli spazi residenziali e commerciali.

Expressed in the warm shades of Marfil, the inspirational purity of marble brings harmony and naturalness to any environment, enveloping residential and commercial spaces with elegant nuances.

Déclinée dans les chaleureuses nuances de Marfil, la pureté inspirée du marbre apporte naturel et harmonie aux espaces résidentiels et commerciaux qu'elle revêt d'élégantes nuances.

Die inspirierende Reinheit von Marmor in den warmen Farbtönen von Marfil verleiht Räumen Harmonie und Natürlichkeit, und gibt Wohn- und Gewerbebereichen ein elegantes Flair.

En los tonos cálidos del Marfil, la pureza inspiradora del mármol plasma los ambientes de armonía y naturaleza, revistiendo con matices elegantes los espacios residenciales y comerciales.

Разнообразные теплые оттенки и вдохновляющая чистота мрамора Marfil придают интерьеру помещений естественную гармонию, подчеркиваемую элегантными цветовыми нюансами облицовочных поверхностей в жилых помещениях и на торговых площадях.







## MARFIL

FLOOR  
PURITY marfil lux 75x150 RT . 30"x60"



FLOOR  
PURITY marfil lux 75x150 RT . 30"x60"





## MARFIL

WALL  
PURITY marfil lux 120x120 RT - 48"x48"  
PURITY marfil struttura fluid 30,5x91,5 RT - 12"x36"  
natural blonde 19,7x120 RT - 7<sup>3</sup>/<sub>4</sub>"x48"  
serie Natural Appeal

FLOOR  
mosaico Spring one 30x30 RT - 12"x12"  
serie Four Seasons One



## MARFIL

WALL  
purity marfil campitura ray oro 30,5x91,5RT . 12"x36"

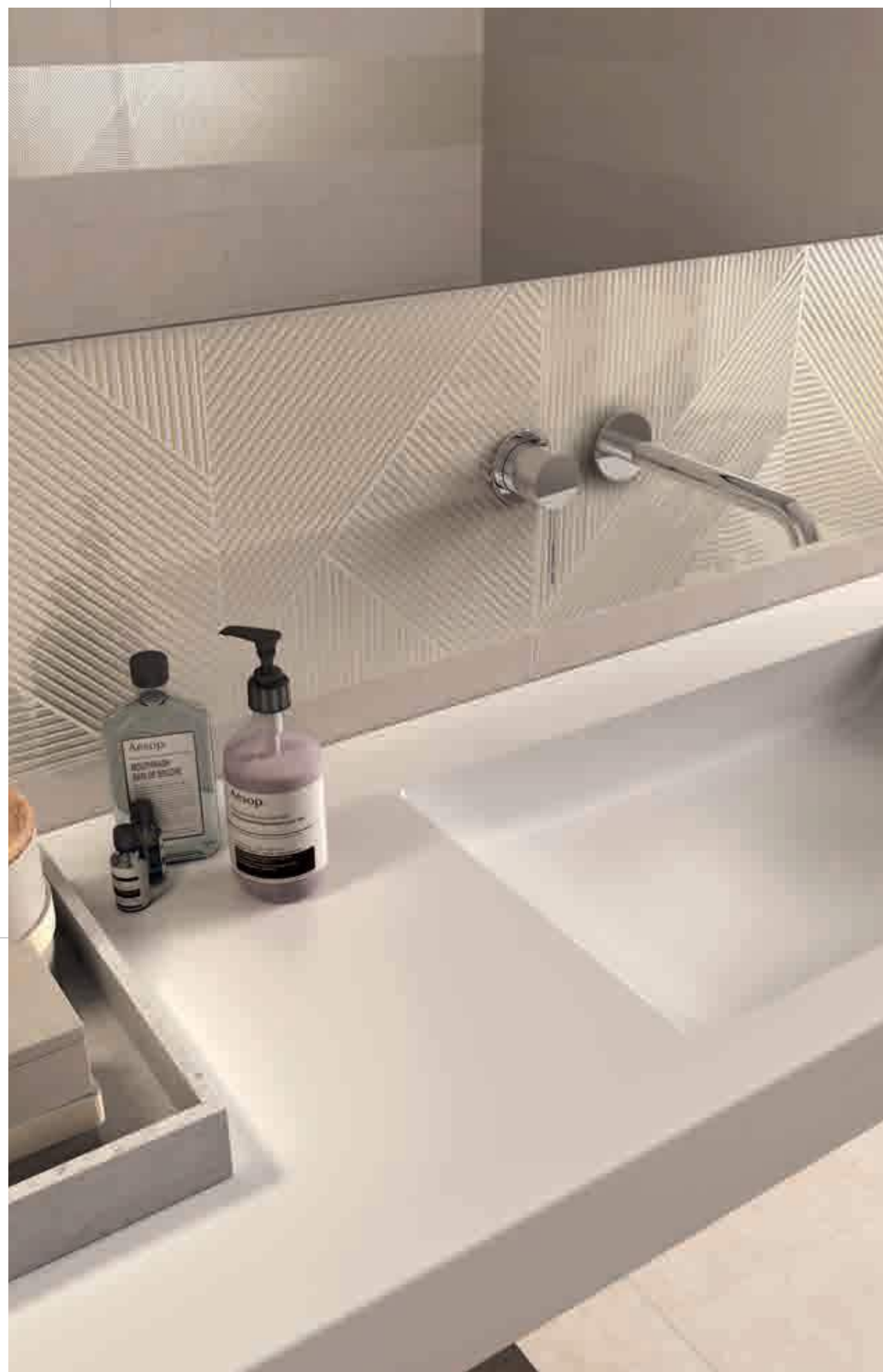

WALL  
PURITY marfil 30,5x91,5 RT . 12"x36"  
PURITY campitura ray oro 30,5x91,5 RT . 12"x36"  
FLOOR  
PURITY marfil lux 75x75 RT . 30"x30"





# LASA



Purity of marble reinterpreta il marmo Lasa, uno dei più pregiati al mondo, apprezzato per il suo aspetto omogeneo, puro e luminoso. Le delicate venature rivelano tutta la storia della materia ed impreziosiscono gli ambienti di spazi residenziali e commerciali.

Purity of Marble reinterprets Lasa marble, one of the finest quality marbles in the world, widely appreciated for its uniform appearance, pure and bright. Its delicate veining reveals the entire story of matter and makes ambiances precious, be they residential or commercial.

Purity of marble réinterprète le marbre Lasa, l'un des plus précieux au monde, apprécié pour son aspect homogène, pur et lumineux. Les délicates veines révèlent toute l'histoire de la matière et subliment les espaces de contextes résidentiels et commerciaux.

Purity of marble interpretiert den Marmor Lasa, einer der schönsten der Welt, hoch geschätzt für sein gleichmäßiges Erscheinungsbild, rein und hell, neu. Die zarten Aderungen enthüllen die ganze Geschichte dieses Werkstoffes und entfallen in Wohn- und Geschäftsräumen zurückhaltenden Luxus.

Purity of marble reinterpreta el mármol Lasa, uno de los más valiosos en el mundo, apreciado por su aspecto homogéneo, puro y luminoso. Las delicadas venas revelan toda la historia del material y enriquecen los ambientes de espacios residenciales y comerciales.

Плитки Purity of marble воспроизводят фактуру мрамора Lasa – одного из самых элитных сортов, высоко ценящегося за его однородный, чистый и светлый вид. Мягкий прожилковый рисунок способен изысканно украсить как жилые, так и коммерческие пространства.



## LASA

FLOOR  
PURITY lasa lux 75x150 RT - 30"x60"  
PURITY lasa lux intreccio decorato 30x30 RT . 12"x12"

WALL  
PURITY lasa struttura net 30x91,5 RT . 12"x36"





## LASA

FLOOR  
PURITY lasa lux 75x150 RT . 30"x60"  
TRAVEL westbrown 19,7x120 RT . 7 3/4"x48"

WALL  
PURITY lasa 30,5x91,5 RT 12"x36"  
PURITY lasa campitura ramage 30,5x91,5 RT . 12"x36"  
PURITY lasa brick 30,5x30,5 RT . 12"x12"  
TRAVEL westbrown 19,7x120 RT . 7 3/4"x48"  
profilo metallo rame 0,5x100 . 0,2"x40"



# LASA

WALL  
PURITY lasa campitura ramage 30,5x91,5 RT . 12"x36"  
PURITY lasa 30,5x91,5 RT . 12"x36"

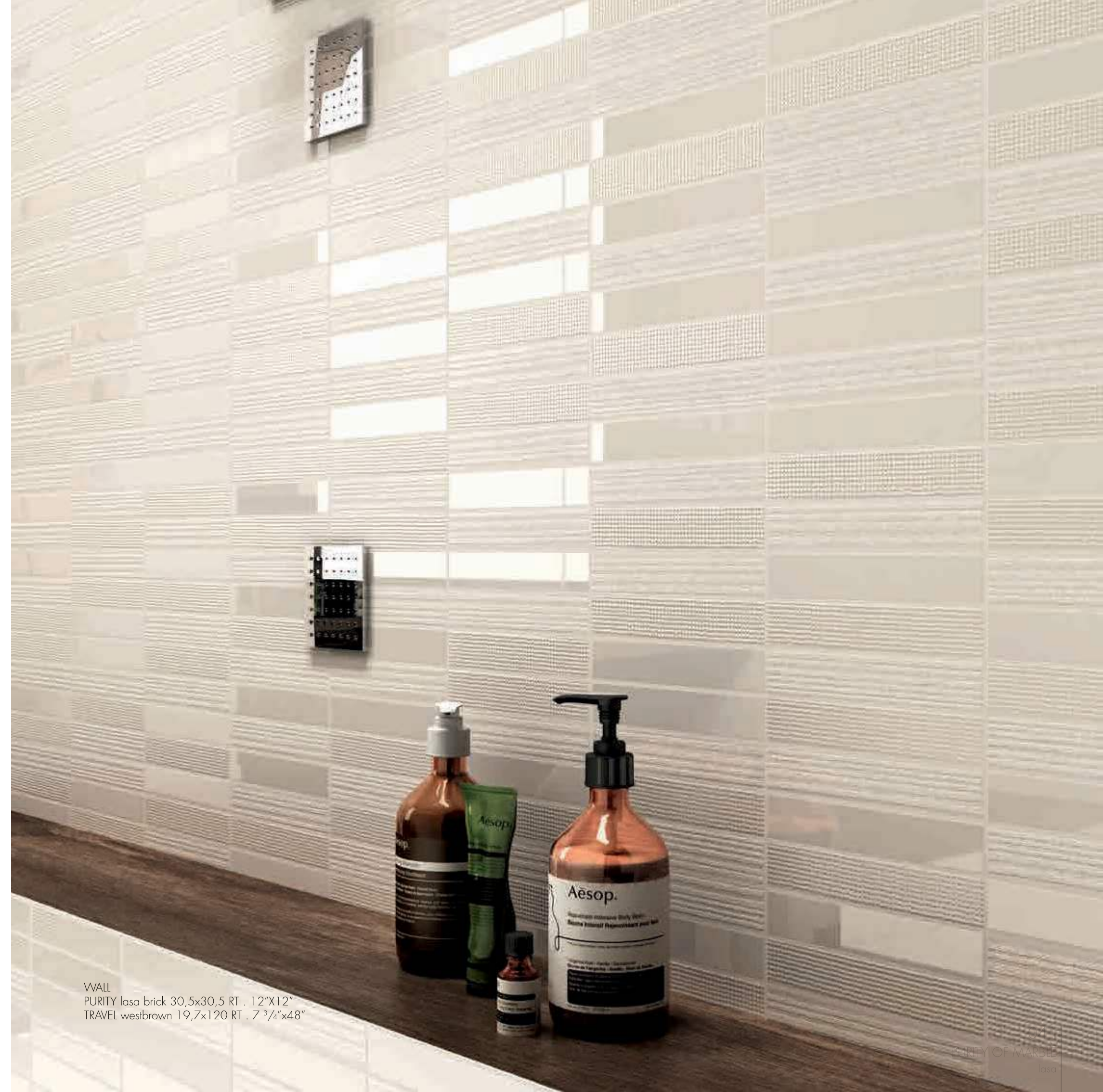

WALL  
PURITY lasa brick 30,5x30,5 RT . 12"x12"  
TRAVEL wesibrown 19,7x120 RT . 7 3/4"x48"





# STATUARIO



Lussuoso, elegante, scultoreo.  
Il marmo Statuario abita gli spazi più raffinati e, grazie alle molteplici venature grigie che attraversano la sua superficie bianca, garantisce dinamicità estetica agli ambienti, arricchendoli di un'impagabile brillantezza ed eleganza.

*Luxurious, elegant and sculptural. Statuario marble embraces the most refined spaces and, thanks to the multiple grey veining that streaks along its white surface, guarantees aesthetic dynamism to the ambiances, enriching them with brilliance and elegance of inestimable value.*

*Luxeux, élégant, sculptural. Le marbre Statuario revêt les espaces les plus raffinés et, grâce aux nombreuses veines grises qui sillonnent sa surface blanche, il garantit un dynamisme esthétique aux espaces, en les enrichissant d'une brillante et élégance uniques.*

*Leuchtend, elegant, plastisch. Der Marmor Statuario gestaltet, dank seiner zahlreichen grauen Aderungen, die sich kunstvoll über die weiße Oberfläche hinwegziehen, raffinierte Umgebungen und sorgt für ästhetische Dynamik von unschätzbare Brillanz und Eleganz.*

*Lujoso, elegante, escultórico. El mármol Statuario habita los espacios más refinados y, gracias a las múltiples venas grises que atraviesan su superficie blanca, garantiza dinamismo estético a los ambientes, enriqueciéndolos con una incomparable brillo y elegancia.*

*Роскошный, элегантный, скульптурный. Мрамор Статуарио, чей белый фон богато испещрен деликатными серыми прожилками, привносит в интерьер яркую и элегантную нотку динамизма.*





044  
PURITY OF MARBLE  
statuario



## STATUARIO

FLOOR  
PURITY statuario lux 120x120 RT - 48"x48"

WALL  
PURITY statuario struttura net decorata glitter argento  
30,5x91,5 RT - 12"x36"  
ART graphite 75x150 RT - 30"x60"  
ART cement 60x60 RT - 24"x24"  
ALL OVER all white lux 75x75 RT - 30"x30"

045  
PURITY OF MARBLE  
statuario





## STATUARIO

FLOOR  
PURITY statuario lux 75x150 RT . 30"x60"

WALL  
ART graphite struttura sign 30,5x91,5 RT . 12"x36"  
serie ART



## STATUARIO

FLOOR  
PURITY statuario lux 75x150 RT . 30"x60"

WALL  
ART graphite struttura sign 30,5x91,5 RT . 12"x36"



FLOOR  
PURITY statuario lux 75x150 RT . 30"x60"





## STATUARIO

FLOOR  
PURITY statuario lux 75x75 RT . 30"x30"  
STONWORK T20 ardesia nera T20 60x120 RT . 24"x48"

WALL  
PURITY statuario 30,5x91,5 RT . 12"x36"  
PURITY statuario struttura net 30,5x91,5 RT . 12"x36"  
STONWORK ardesia nera 60x120 RT - 24"x48"



# IMPERIAL GREY



L'intensità del grigio e la profondità delle venature bianche caratterizzano il marmo Imperial Grey. La brillantezza e la raffinatezza della sua superficie rendono gli ambienti accoglienti ed eleganti, rivestendo di luce gli spazi.

Imperial Grey marble is characterised by an intense grey colour and deep white vein markings. Its bright and elegant surface makes the rooms welcoming and elegant, enveloping the spaces with light.

L'intensité du gris et la profondeur des veinures blanches caractérisent le marbre Imperial Grey. L'éclat et le raffinement de sa surface jettent leur lumière sur les espaces qu'ils dotent d'une atmosphère accueillante et élégante.

Die Intensität von Grau und die Tiefe der weißen Äderungen charakterisieren Imperial Grey. Der Glanz und die Eleganz der Oberfläche machen Ambiente gemütlich und elegant und bringen Licht in die Räume.

La intensidad del gris y la profundidad de los veteados blancos caracterizan el mármol Imperial Grey. El brillo y la refinación de su superficie visitan los espacios con un aspecto acogedor y elegante, revistiéndolos de luz.

Насыщенный серый цвет и глубокие белые прожилки отличают мрамор Imperial Grey. Изысканно блестящая поверхность мрамора делает помещения уютными и элегантными, наполненными воздухом и светом.







## IMPERIAL GREY

FLOOR  
PURITY imperial grey lux 75x150 RT . 30"x60"



FLOOR  
PURITY imperial grey lux 75x150 RT . 30"x60"  
PURITY imperial grey lux gradone c/profilo incollato 33x120 RT - 13,2"x48"



## IMPERIAL GREY

WALL  
PURITY statuario 3D line 32x45 RT . 12,6"x18"  
FLOOR  
PURITY imperial grey lux 120x120 RT . 48"x48"



WALL  
PURITY statuario 3D line 32x45 RT . 12,6"x18"

FLOOR  
PURITY imperial grey lux 120x120 RT . 48"x48"



# PURITY OF MARBLE

**LUX 120x120RT** . 9mm ⇄ **LUX 75x150RT** . **LUX 75x75RT** . 9,5mm ⇄  
**LUX 60x60RT** . **LUX 30x60RT** . 9,5mm ⇄

GRES PORCELLANATO . Porcelain stoneware

EN 14411 Allegato G . Piastrelle di ceramica pressate a secco con basso assorbimento d'acqua (E ≤ 0,5%)  
 Gruppo B la GL (smaltate, glazed)

**60x60RT** . **30x60RT** . 9,5mm ⇄

GRES PORCELLANATO . Porcelain stoneware

EN 14411 Allegato G . Piastrelle di ceramica pressate a secco con basso assorbimento d'acqua (E ≤ 0,5%)  
 Gruppo B la UGL (non smaltate, unglazed)

**30,5x91,5RT** . 8,5mm ⇄

RIVESTIMENTO IN PASTA BIANCA . Revêtements en pâte blanche . Weißscherbiger wandfliesen  
 White body wall tiles . Revestimientos en pasta blanca . Настенная плитка из белой глины

EN 14411 Allegato L . Piastrelle di ceramica pressate a secco (E > 10 %)  
 Gruppo B III GL (smaltate, émaillé, glasierte, glazed, esmaltado, Глазурованные)

## ROYAL BEIGE



PURITY ROYAL BEIGE 75x150 RT LUX - 30"x60"



PURITY ROYAL BEIGE 75x75 RT LUX - 30"x30"



PURITY ROYAL BEIGE OTTAGONA  
 60x60 RT LUX - 24"x24"

TOZZETTO  
 marmo  
 Travertino Noce  
 6x6 - 2,3"x2,3"

TOZZETTO  
 marmo  
 Emperador  
 6x6 - 2,3"x2,3"



PURITY ROYAL BEIGE 60x60 RT LUX - 24"x24"



PURITY ROYAL BEIGE  
 30x60 RT LUX - 12"x24"



PURITY ROYAL BEIGE  
 INTRECCIO DECORATO  
 30x30 LUX - 12"x12"

## NATURALE



PURITY ROYAL BEIGE 60x60 RT - 24"x24"



PURITY ROYAL BEIGE 30x60 RT - 12"x24"



PURITY ROYAL BEIGE Mosaico  
 30x30 RT - 12"x12"



PURITY ROYAL BEIGE 3D LINE  
 32x45 RT . 12,6"x18"



PURITY ROYAL BEIGE 30,5x91,5 RT - 12"x36"



PURITY ROYAL BEIGE struttura FLUID 30,5x91,5 RT - 12"x36"



PURITY ROYAL BEIGE struttura NET 30,5x91,5 RT - 12"x36"



PURITY ROYAL BEIGE struttura NET GLITTER RAME 30,5x91,5 RT - 12"x36"



PURITY ROYAL BEIGE campitura RAMAGE 30,5x91,5 RT - 12"x36"



PURITY campitura RAY ORO 30,5x91,5 RT - 12"x36"

profilo metallo rame  
 0,5x100 RT - 0,2"x40"



PURITY spigolo HONEY  
 0,8x30,5 - 0,3"x12"

\* PURITY ang/est spigolo HONEY  
 h 0,8 - 0,3"



PURITY ROYAL BEIGE brick  
 30,5x30,5 RT - 12"x12"

# PURITY OF MARBLE

**LUX 120x120RT** . 9mm ⇄ **LUX 75x150RT** . **LUX 75x75RT** . 9,5mm ⇄

**LUX 60x60RT** . **LUX 30x60RT** . 9,5mm ⇄

GRES PORCELLANATO . Porcelain stoneware

EN 14411 Allegato G . Piastrelle di ceramica pressate a secco con basso assorbimento d'acqua (E ≤ 0,5%) Gruppo B la GL (smaltate, glazed)

**60x60RT** . **30x60RT** . 9,5mm ⇄

GRES PORCELLANATO . Porcelain stoneware

EN 14411 Allegato G . Piastrelle di ceramica pressate a secco con basso assorbimento d'acqua (E ≤ 0,5%) Gruppo B la UGL (non smaltate, unglazed)

**30,5x91,5RT** . 8,5mm ⇄

RIVESTIMENTO IN PASTA BIANCA . Revêtements en pâte blanche . Weißscherbiger wandfliesen  
White body wall tiles . Revestimientos en pasta blanca . Настенная плитка из белой глины

EN 14411 Allegato L . Piastrelle di ceramica pressate a secco (E > 10 %) Gruppo B III GL (smaltate, émaillé, glasierte, glazed, esmaltado, Глазурованные)

## CALACATTA



PURITY CALACATTA 75x150 RT LUX - 30"x60"



PURITY CALACATTA 75x75 RT LUX - 30"x30"



PURITY CALACATTA OTTAGONA 60x60 RT LUX - 24"x24"

TOZZETTO  
marmo  
Travertino Noce  
6x6 - 2,3"x2,3"

TOZZETTO  
marmo  
Emperador  
6x6 - 2,3"x2,3"



PURITY CALACATTA 60x60 RT LUX - 24"x24"



PURITY CALACATTA 30x60 RT LUX - 12"x24"



PURITY CALACATTA INTRECCIO DECORATO 30x30 LUX - 12"x12"

## NATURALE



PURITY CALACATTA 60x60 RT - 24"x24"



PURITY CALACATTA 30x60 RT - 12"x24"



PURITY CALACATTA Mosaico 30x30 RT - 12"x12"



PURITY CALACATTA 30,5x91,5 RT - 12"x36"



PURITY CALACATTA struttura FLUID 30,5x91,5 RT - 12"x36"



PURITY CALACATTA struttura NET 30,5x91,5 RT - 12"x36"



PURITY CALACATTA struttura NET GLITTER ORO 30,5x91,5 RT - 12"x36"



PURITY CALACATTA campitura RAMAGE 30,5x91,5 RT - 12"x36"



PURITY campitura RAY ORO 30,5x91,5 RT - 12"x36"

profilo metallo oro  
0,5x100 RT - 0,2"x40"



# PURITY OF MARBLE

**LUX 120x120RT** . 9mm ⇄ **LUX 75x150RT** . **LUX 75x75RT** . 9,5mm ⇄

**LUX 60x60RT** . **LUX 30x60RT** . 9,5mm ⇄

GRES PORCELLANATO . Porcelain stoneware

EN 14411 Allegato G\_Piastrelle di ceramica pressate a secco con basso assorbimento d'acqua (E ≤ 0,5%) Gruppo B la GL (smaltate, glazed)

**60x60RT** . **30x60RT** . 9,5mm ⇄

GRES PORCELLANATO . Porcelain stoneware

EN 14411 Allegato G\_Piastrelle di ceramica pressate a secco con basso assorbimento d'acqua (E ≤ 0,5%) Gruppo B la UGL (non smaltate, unglazed)

**30,5x91,5RT** . 8,5mm ⇄

RIVESTIMENTO IN PASTA BIANCA . Revêtements en pâte blanche . Weißscherbiger wandfliesen  
White body wall tiles . Revestimientos en pasta blanca . Настенная плитка из белой глины

EN 14411 Allegato L\_Piastrelle di ceramica pressate a secco (E > 10 %) Gruppo B III GL (smaltate, émaillé, glasierte, glazed, esmaltado, Глазурованные)

## MARFIL



PURITY MARFIL 75x150 RT LUX - 30"x60"



PURITY MARFIL 75x75 RT LUX - 30"x30"



PURITY MARFIL OTTAGONA  
60x60 RT LUX - 24"x24"

TOZZETTO  
marmo  
Travertino Noce  
6x6 - 2,3"x2,3"

TOZZETTO  
marmo  
Emperador  
6x6 - 2,3"x2,3"



PURITY MARFIL 60x60 RT LUX - 24"x24"

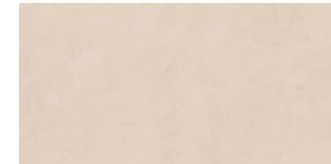

PURITY MARFIL  
30x60 RT LUX - 12"x24"



PURITY MARFIL  
INTRECCIO DECORATO  
30x30 LUX - 12"x12"

## NATURALE



PURITY MARFIL 60x60 RT - 24"x24"



PURITY MARFIL 30x60 RT - 12"x24"



PURITY MARFIL Mosaico  
30x30 RT - 12"x12"



PURITY MARFIL 30,5x91,5 RT - 12"x36"



PURITY MARFIL struttura FLUID 30,5x91,5 RT - 12"x36"



PURITY MARFIL struttura NET 30,5x91,5 RT - 12"x36"



PURITY MARFIL struttura NET GLITTER ORO 30,5x91,5 RT - 12"x36"



PURITY MARFIL campitura RAMAGE 30,5x91,5 RT - 12"x36"



PURITY campitura RAY ORO 30,5x91,5 RT - 12"x36"



PURITY spigolo HONEY  
0,8x30,5 - 0,3"x12"

\* PURITY ang/est spigolo HONEY  
h 0,8 - 0,3"



PURITY MARFIL brick  
30,5x30,5 RT - 12"x12"

profilo metallo oro  
0,5x100 RT - 0,2"x40"

# PURITY OF MARBLE

**LUX 120x120RT** . 9mm ⇄ **LUX 75x150RT** . **LUX 75x75RT** . 9,5mm ⇄

**LUX 60x60RT** . **LUX 30x60RT** . 9,5mm ⇄

GRES PORCELLANATO . Porcelain stoneware

EN 14411 Allegato G . Piastrelle di ceramica pressate a secco con basso assorbimento d'acqua (E ≤ 0,5%) Gruppo B la GL (smaltate, glazed)

**60x60RT** . **30x60RT** . 9,5mm ⇄

GRES PORCELLANATO . Porcelain stoneware

EN 14411 Allegato G . Piastrelle di ceramica pressate a secco con basso assorbimento d'acqua (E ≤ 0,5%) Gruppo B la UGL (non smaltate, unglazed)

**30,5x91,5RT** . 8,5mm ⇄

RIVESTIMENTO IN PASTA BIANCA . Revêtements en pâte blanche . Weißscherbiger wandfliesen  
White body wall tiles . Revestimientos en pasta blanca . Настенная плитка из белой глины

EN 14411 Allegato L . Piastrelle di ceramica pressate a secco (E > 10 %) Gruppo BIII GL (smaltate, émaillé, glasierte, glazed, esmaltado, Глазурованные)

## LASA



PURITY LASA 75x150 RT LUX - 30"x60"



PURITY LASA 75x75 RT LUX - 30"x30"



PURITY LASA OTTAGONA  
60x60 RT LUX - 24"x24"

TOZZETTO  
marmo  
Travertino Noce  
6x6 - 2,3"x2,3"

TOZZETTO  
marmo  
Emperador  
6x6 - 2,3"x2,3"



PURITY LASA 60x60 RT LUX - 24"x24"

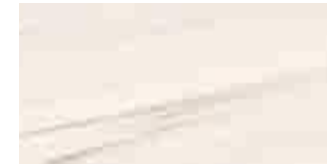

PURITY LASA  
30x60 RT LUX - 12"x24"



PURITY LASA  
INTRECCIO DECORATO  
30x30 LUX - 12"x12"

## NATURALE



PURITY LASA 60x60 RT - 24"x24"



PURITY LASA 30x60 RT - 12"x24"



PURITY LASA Mosaico  
30x30 RT - 12"x12"

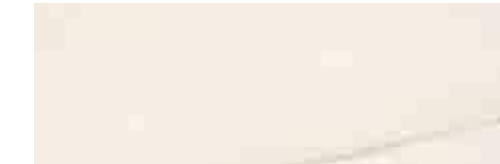

PURITY LASA 30,5x91,5 RT - 12"x36"



PURITY LASA struttura FLUID 30,5x91,5 RT - 12"x36"



PURITY LASA struttura NET 30,5x91,5 RT - 12"x36"



PURITY LASA struttura NET GLITTER RAME 30,5x91,5 RT - 12"x36"



PURITY LASA campitura RAMAGE 30,5x91,5 RT - 12"x36"



PURITY campitura RAY ORO 30,5x91,5 RT - 12"x36"

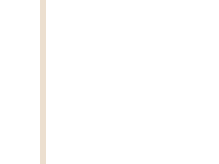

PURITY spigolo MILK  
0,8x30,5 - 0,3"x12"



PURITY LASA brick  
30,5x30,5 RT - 12"x12"

PURITY ang/est spigolo MILK  
h 0,8 - 0,3"

profilo metallo rame  
0,5x100 RT - 0,2"x40"



# PURITY OF MARBLE

**LUX 120x120RT** . 9mm ⇄ **LUX 75x150RT** . **LUX 75x75RT** . 9,5mm ⇄

**LUX 60x60RT** . **LUX 30x60RT** . 9,5mm ⇄

GRES PORCELLANATO . Porcelain stoneware

EN 14411 Allegato G . Piastrelle di ceramica pressate a secco con basso assorbimento d'acqua (E ≤ 0,5%) Gruppo B la GL (smaltate, glazed)

**60x60RT** . **30x60RT** . 9,5mm ⇄

GRES PORCELLANATO . Porcelain stoneware

EN 14411 Allegato G . Piastrelle di ceramica pressate a secco con basso assorbimento d'acqua (E ≤ 0,5%) Gruppo B la UGL (non smaltate, unglazed)

**30,5x91,5RT** . 8,5mm ⇄

RIVESTIMENTO IN PASTA BIANCA . Revêtements en pâte blanche . Weißscherbiger wandfliesen  
White body wall tiles . Revestimientos en pasta blanca . Настенная плитка из белой глины

EN 14411 Allegato L . Piastrelle di ceramica pressate a secco (E > 10 %) Gruppo BIII GL (smaltate, émaillé, glasierte, glazed, esmaltado, Глазурованные)

## STATUARIO



PURITY STATUARIO 75x150 RT LUX - 30"x60"



PURITY STATUARIO 75x75 RT LUX - 30"x30"



PURITY STATUARIO OTTAGONA 60x60 RT LUX - 24"x24"

■  
TOZZETTO  
MARMO  
NERO MARQUINIA  
6x6 - 2,3"x2,3"



PURITY STATUARIO 60x60 RT LUX - 24"x24"



PURITY STATUARIO 30x60 RT LUX - 12"x24"



PURITY STATUARIO INTRECCIO DECORATO 30x30 LUX - 12"x12"

## NATURALE



PURITY STATUARIO 60x60 RT - 24"x24"



PURITY STATUARIO 30x60 RT - 12"x24"



PURITY STATUARIO Mosaico 30x30 RT - 12"x12"



PURITY STATUARIO 3D LINE 32x45 RT . 12,6"x18"



PURITY STATUARIO 30,5x91,5 RT - 12"x36"



PURITY STATUARIO struttura FLUID 30,5x91,5 RT - 12"x36"



PURITY STATUARIO struttura NET 30,5x91,5 RT - 12"x36"



PURITY STATUARIO struttura NET GLITTER ARGENTO 30,5x91,5 RT - 12"x36"



PURITY STATUARIO campitura RAMAGE 30,5x91,5 RT - 12"x36"



PURITY campitura RAY ARGENTO 30,5x91,5 RT - 12"x36"

profilo metallo argento 0,5x100 RT - 0,2"x40"

# PURITY OF MARBLE

**LUX 120x120RT** . 9mm ➔ **LUX 75x150RT** . **LUX 75x75RT** . 9,5mm ➔  
**LUX 60x60RT** . **LUX 30x60RT** . 9,5mm ➔

GRES PORCELLANATO . Porcelain stoneware

EN 14411 Allegato G\_Piastrelle di ceramica pressate a secco con basso assorbimento d'acqua (E ≤ 0,5%)  
Gruppo B la GL (smaltate, glazed)

**60x60RT** . **30x60RT** . 9,5mm ➔

GRES PORCELLANATO . Porcelain stoneware

EN 14411 Allegato G\_Piastrelle di ceramica pressate a secco con basso assorbimento d'acqua (E ≤ 0,5%)  
Gruppo B la UGL (non smaltate, unglazed)

AVVERTENZE PER LA POSA . RECOMMENDATIONS FOR INSTALLATION .

Recommandations pour la pose . Verlegetipps . Advertencias de colocación . Рекомендации по укладке

## IMPERIAL GREY



PURITY IMPERIAL GREY 75x150 RT LUX - 30"x60"



PURITY IMPERIAL GREY 75x75 RT LUX - 30"x30"



PURITY IMPERIAL GREY OTTAGONA 60x60 RT LUX - 24"x24"

■  
TOZZETTO  
MARMO  
NERO MARQUINIA  
6x6 - 2,3"x2,3"



PURITY IMPERIAL GREY 60x60 RT LUX - 24"x24"



PURITY IMPERIAL GREY 30x60 RT LUX - 12"x24"



PURITY IMPERIAL GREY INTRECCIO DECORATO 30x30 LUX - 12"x12"

## NATURALE



PURITY IMPERIAL GREY 60x60 RT - 24"x24"



PURITY IMPERIAL GREY 30x60 RT - 12"x24"



PURITY IMPERIAL GREY Mosaico 30x30 RT - 12"x12"



PURITY IMPERIAL GREY 3D LINE 32x45 RT . 12,6"x18"

Per la posa del materiale rettificato si consiglia una fuga minima di 2 mm.

As for rectified materials, it is strongly recommended a minimum of 2 mm joint.

Pour poser du matériel rectifié nous vous conseillons un joint minimum de 2 mm.

Für die Verlegung des kalibrierten Material empfehlen wir einen Mindestfuge von 2 mm.

Para la colocación de material rectificado se aconsejan juntas mínima de 2 mm.

Ретифицированную плитку рекомендуется укладывать со швом 2 мм.

La finitura superficiale "LUX" è una nuova tecnica di lappatura di ceramiche Supergres, caratterizzata da una superficie a lappatura integrale che esalta i dettagli della grafica. Le piccole picchiettature, le discontinuità e le leggere ondulazioni della superficie del prodotto sono volute per riprodurre fedelmente l'aspetto reale delle pietre e dei marmi antichi levigati donando al prodotto un aspetto ancora più naturale. La finitura LUX è consigliata per l'utilizzo a pavimento negli ambienti residenziali e negli ambienti dove non siano richieste delle particolari prestazioni antiscivolo. Per le sue caratteristiche, la finitura LUX è raccomandata solo in ambienti interni e non a diretto contatto con l'esterno, in modo da preservare la brillantezza della superficie

The "LUX" surface finish is a new honing technique by Ceramiche Supergres that sets itself apart thanks to an integral honing on the surface that exalts the graphic details. The light speckles, the random effect and slight waves on the surface of the product are intentional and created to faithfully reproduce the aspect of age-old polished stones and marble, giving the product an even more natural look. The LUX surface finish is recommended for floor application in residential venues and in locations where special anti-slip performance is not required. Due to these features, in order to maintain the brilliance of the LUX surface finish, it is only suitable for indoor use and not for use in direct contact with outdoor areas.

La finition superficielle "LUX" est une nouvelle technique de rodage de ceramiche Supergres, caractérisée par une surface intégralement rodée qui exalte les détails du graphisme. Les petites tiquettes, les discontinuités et les légères ondulations de la surface du produit sont réalisées pour reproduire fidèlement l'aspect réel des pierres et des marbres antiques polis, en donnant au produit un aspect encore plus naturel. La finition LUX est conseillée pour l'application au sol dans les espaces résidentiels et dans les espaces qui n'exigent pas la finition antidérapante. Pour ses caractéristiques, la finition LUX est conseillée seulement pour des espaces intérieurs qui ne sont pas en contact direct avec l'extérieur, de façon à préserver l'éclat de la surface.

Die Oberfläche "LUX" wird aufgrund einer neuen Lápptechnik von Ceramiche Supergres erhalten und kennzeichnet sich durch integral geläppte Oberflächen, wodurch die Details der Grafiken besonders hervorgehoben werden. Die kleinen Sprengel, die Diskontinuitäten und die sanften Wellen der Oberfläche des Produkts sind gewollt und ahmen naturgetreu das wirkliche Aussehen der Natursteine und der polierten, antiken Marmorarten nach, während sie dadurch dem Produkt eine noch natürlichere Optik verleihen. Die Oberfläche LUX ist für den Einsatz als Fußboden in Wohnambientes und in Umgebungen, in denen keine speziellen rutschhemmenden Leistungen erforderlich sind empfohlen. Aufgrund ihrer Eigenschaften ist die Oberfläche LUX nur für Innenräume geeignet, die nicht in direktem Kontakt mit dem Außenbereich kommen, so dass der Glanz der Oberfläche erhalten bleibt.

El acabado superficial "LUX" es una nueva técnica de pulido de ceramiche Supergres, caracterizada por una superficie a pulido integral que destaca los detalles gráficos. Los pequeños punteados, las discontinuidades y las leves ondulaciones de la superficie del producto son intencionales para reproducir fielmente el aspecto real de las piedras y de los mármoles antiguos pulidos, brindando al producto un aspecto aún más natural. El acabado LUX es aconsejado para el empleo en pavimento en los ambientes residenciales y en los ambientes en donde no se requieran especiales prestaciones antideslizamiento. Por sus características, el acabado LUX es recomendado sólo en ambientes interiores y no en contacto directo con el exterior, a fin de preservar el brillo de la superficie.

Поверхностная отделка LUX является результатом применения нового метода шлифования Ceramiche Supergres, позволяющего эффектно подчеркнуть все детали рисунка. Небольшие крапинки и легкие неровности поверхности созданы намеренно для точной имитации вида камней и старинных полированных мраморных покрытий и имеют целью придать изделиям предельно натуральный вид. Плитки с поверхностью LUX рекомендованы для облицовки полов в жилых интерьерах и интерьерах, где от покрытий не требуется особых показателей сопротивления скольжению. Для сохранения блеска плитки с поверхностью LUX рекомендуется укладывать только в интерьерах, к которым нет прямого доступа с улицы.



# PURITY OF MARBLE

**LUX 120x120RT** . 9mm  $\rightleftharpoons$  **LUX 75x150RT** . **LUX 75x75RT** . 9,5mm  $\rightleftharpoons$   
**LUX 60x60RT** . **LUX 30x60RT** . 9,5mm  $\rightleftharpoons$

GRES PORCELLANATO . Porcelain stoneware

EN 14411 Allegato G . Piastrelle di ceramica pressate a secco con basso assorbimento d'acqua (E ≤ 0,5%)  
 Gruppo B la GL (smaltate, glazed)

**60x60RT** . **30x60RT** . 9,5mm  $\rightleftharpoons$

GRES PORCELLANATO . Porcelain stoneware

EN 14411 Allegato G . Piastrelle di ceramica pressate a secco con basso assorbimento d'acqua (E ≤ 0,5%)  
 Gruppo B la UGL (non smaltate, unglazed)

PEZZI SPECIALI FINITURA NATURALE . Trims . Pièces Spéciales . Formstücke . Специальные изделия

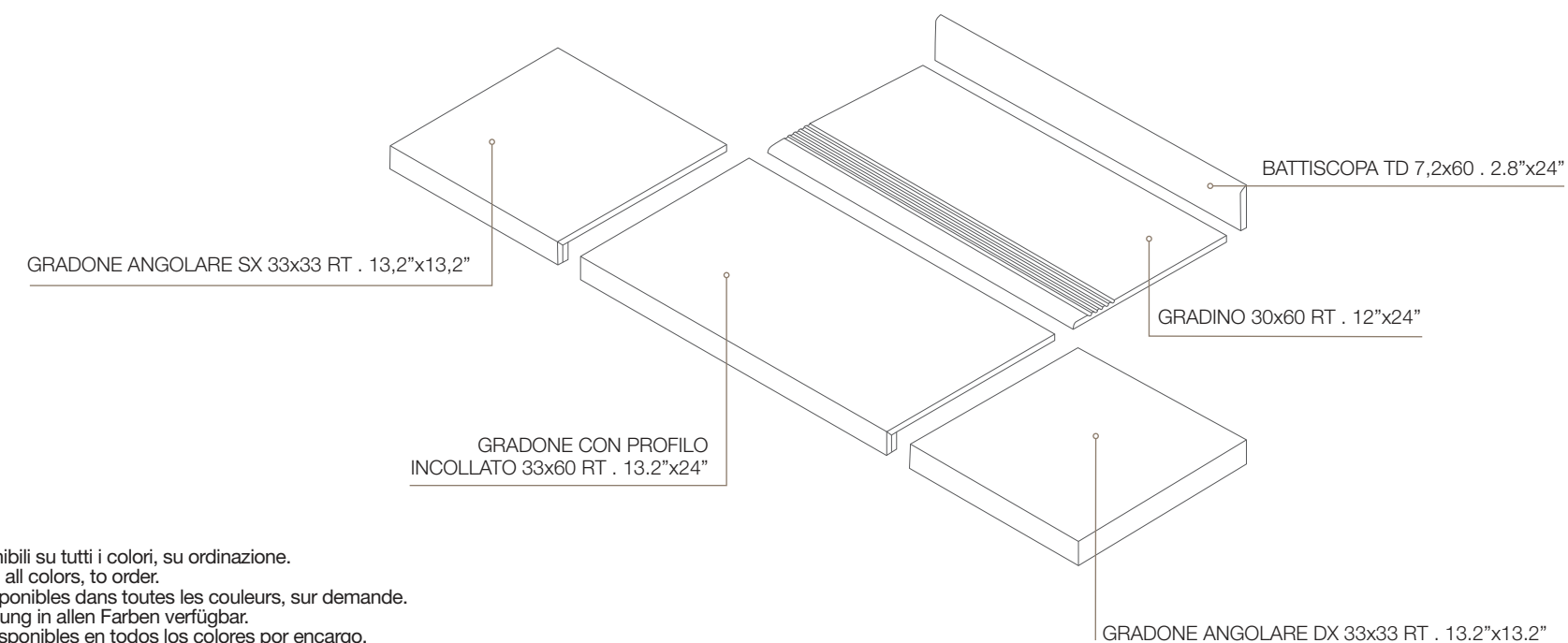

Pezzi speciali disponibili su tutti i colori, su ordinazione.  
 Trim tiles available in all colors, to order.  
 Pièces spéciales disponibles dans toutes les couleurs, sur demande.  
 Formteile auf Bestellung in allen Farben verfügbar.  
 Piezas especiales disponibles en todos los colores por encargo.  
 Специальные элементы доступны для всех цветов по запросу.

PEZZI SPECIALI FINITURA LUX . Trims . Pièces Spéciales . Formstücke . Специальные изделия

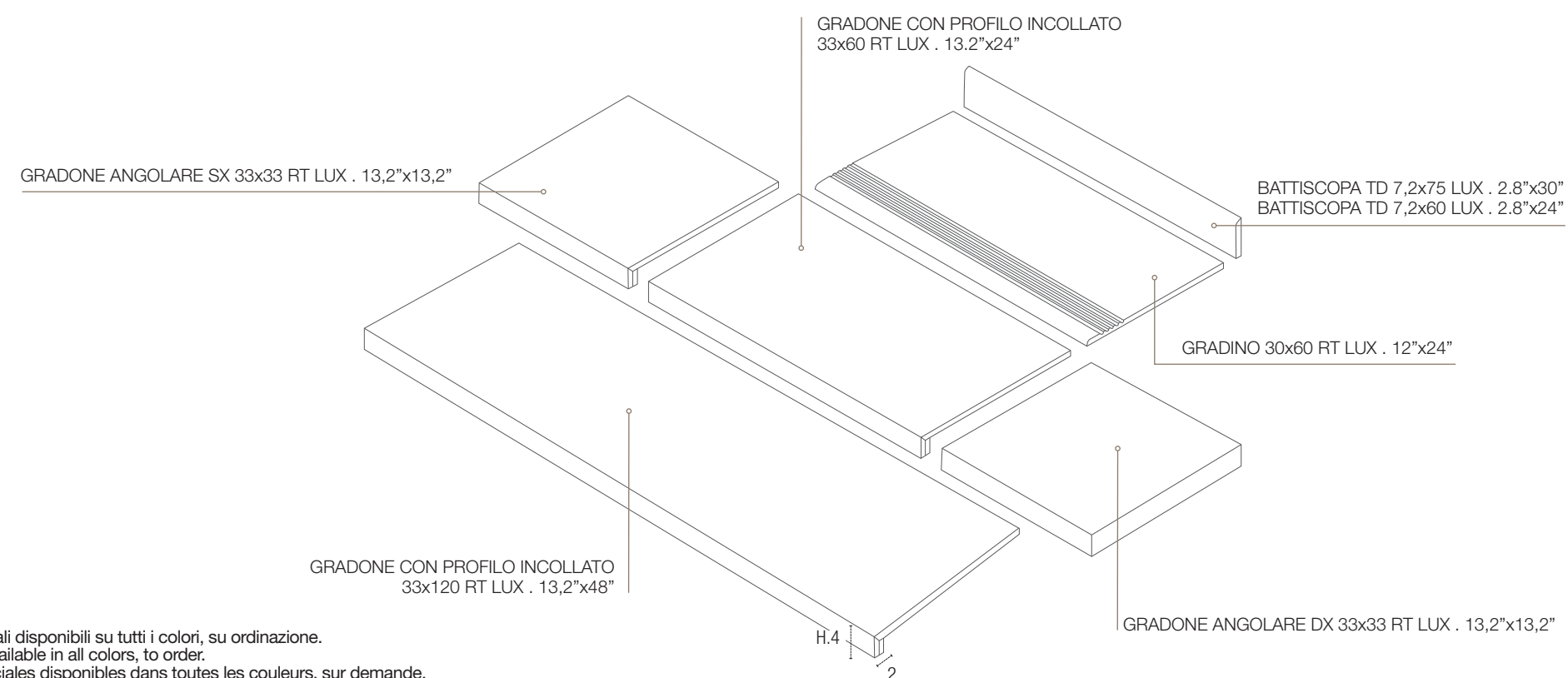

Pezzi speciali disponibili su tutti i colori, su ordinazione.  
 Trim tiles available in all colors, to order.  
 Pièces spéciales disponibles dans toutes les couleurs, sur demande.  
 Formteile auf Bestellung in allen Farben verfügbar.  
 Piezas especiales disponibles en todos los colores por encargo.  
 Специальные элементы доступны для всех цветов по запросу.



FLOOR  
 PURITY calacatta lux gradone con profilo incollato  
 33x120 . 13,2"x48"

# PURITY OF MARBLE

**LUX 120x120RT** . 9mm ➔ **LUX 75x150RT** . **LUX 75x75RT** . 9,5mm ➔

**LUX 60x60RT** . **LUX 30x60RT** . 9,5mm ➔

GRES PORCELLANATO . Porcelain stoneware

EN 14411 Allegato G\_Piastrelle di ceramica pressate a secco con basso assorbimento d'acqua (E ≤ 0,5%) Gruppo B la GL (smaltate, glazed)

**60x60RT** . **30x60RT** . 9,5mm ➔

GRES PORCELLANATO . Porcelain stoneware

EN 14411 Allegato G\_Piastrelle di ceramica pressate a secco con basso assorbimento d'acqua (E ≤ 0,5%) Gruppo B la UGL (non smaltate, unglazed)

IMBALLAGGI . Emballage . Verpackung . Packing . Embalaje . Verpackung . Упаковка

	pz/box	mq/box	kg/box	box/plt	mq/plt	kg/plt	spessore
120x120 RT LUX	2	2,88	58,00	20	57,60	1172	9 mm
75x150 RT LUX	1	1,125	24,00	25	28,13	612	9,5 mm
75x75 RT LUX	2	1,125	24,00	42	47,25	1020	9,5 mm
60x60 RT LUX	3	1,08	23,00	40	43,20	932	9,5 mm
30x60 RT LUX	6	1,08	23,40	40	43,20	948	9,5 mm
ottagona 60x60 RT LUX	3	1,069	21,50	40	42,76	872	9,5 mm
6x6 tozzetto marmo	4						7,5 mm
60x60 RT	3	1,08	23,00	40	43,20	932	9,5 mm
30x60 RT	6	1,08	23,40	40	43,20	948	9,5 mm
32x45 RT 3D LINE	6	0,86	23,00	52	44,93	1210	
30x30 RT LUX intreccio decorato	6	0,54	11,20				
30x30 RT mosaico	10	0,90	17,00	30	27,00	525	
7,2x60 battiscopa	10	6,00 ml	9,40	70	420,00 ml	673	
7,2x60 battiscopa LUX	10	6,00 ml	9,40	70	420,00 ml	673	
7,2x75 battiscopa LUX	10	7,50 ml	11,00	63	472,50 ml	705	
33x120 RT gradone LUX c/profilo incollato	2						
33x60 RT gradone LUX c/profilo incollato	4						
33x33 RT LUX ang/gradone DX c/pr.inc.	4						
33x33 RT LUX ang/gradone SX c/pr.inc.	4						
33x60 RT gradone c/profilo incollato	4						
33x33 RT angolare gradone DX c/pr.inc.	4						
33x33 RT angolare gradone SX c/pr.inc.	4						
30x60 RT gradino LUX	6						
30x60 RT gradino	6						

# PURITY OF MARBLE

**30,5x91,5RT** . 8,5mm ➔

RIVESTIMENTO IN PASTA BIANCA . Revêtements en pâte blanche . Weißscherbiger wandfliesen  
White body wall tiles . Revestimientos en pasta blanca . Настенная плитка из белой глины

EN 14411 Allegato L\_Piastrelle di ceramica pressate a secco (E > 10 %) Gruppo BIII GL (smaltate, émailé, glasierte, glazed, esmaltado, Глазурованные)

IMBALLAGGI . Emballage . Verpackung . Packing . Embalaje . Verpackung . Упаковка

	pz/box	mq/box	kg/box	box/plt	mq/plt	kg/plt	spessore
30,5X91,5 RT	5	1,40	21,00	42	58,60	894	8,5 mm
30,5x91,5 RT strutt.FLUID	4	1,12	20,50	42	46,87	873	8,5 mm*
30,5x91,5 RT strutt.NET	4	1,12	19,50	42	46,87	831	8,5 mm*
30,5x91,5 RT strutt.NET decorata	2						
30,5X91,5 RT campitura ramage	2						
30,5X91,5 RT campitura RAY	2						
0,5x100 profilo metallo	3						8 mm
30,5x30,5 RT brick su rete	6	0,56	7,80	42	23,44	340	
spigolo 0.8x30.5	6						
ang/est spigolo h. 0.8	4						

\* **Spessore riferito al fondo liscio equivalente.**

Thickness refers to the equivalent smooth background

Épaisseur se rapportant au carreau lisse équivalent

Die Stärke bezieht sich auf die entsprechende glatte Grundfliese.

Espesor referido al fondo liso equivalente

Толщина эквивалентной плитки с гладким основанием



**GRES PORCELLANATO** . Grès cérame . Feinsteinzeug  
**Porcelain stoneware** . Gres porcelánico . Керамогранит

Norma di riferimento: **EN 14411 (ISO 13006) Allegato G - Piastrelle di ceramica pressate a secco con basso assorbimento d'acqua (Ev 0,5%)**

Norme retenue: EN 14411 (ISO 13006) Annexe G - Carreaux céramiques pressés à sec avec faible absorption d'eau (Ev ≤ 0,5%) . Besugznorm: EN 14411 (ISO 13006) Anlage G - Trockengepresste keramische Fliesen und Platten mit niedriger Wasseraufnahme (Ev ≤ 0,5%) . Reference standard: EN 14411 (ISO 13006) Appendix G - Dry pressed ceramic tiles with low water absorption (Ev ≤ 0,5%) . Norma de referencia: EN 14411 (ISO 13006) Anexo G - Baldosas de cerámica prensadas en seco (E ≤ 0,5%) . Соответствует нормe EN 14411 (ISO 13006) Керамические плитки, спрессованные всухую, с низким водопоглощением (Ev ≤ 0,5 %)

## GRUPPO B Ia

CARATTERISTICHE TECNICHE . TECHNICAL CHARACTERISTICS Características técnicas . Technische eigenschaften Características técnicas . Технические характеристики	NORMA . NORMS Normes . Normen Normas . Стандарт	REQUISITI RICHIESTI . REQUIREMENTS Conditions requisés . Geforderte eigenschaften Valor solicitud . Значение, требуемое в соответствии с нормами			VALORE MEDIO SUPERGRES * Valeur moyenne . Average rating Durchschnittswert . среднее значение	
		RETTIFICATI	7 cm ≤ N < 15 cm	N > 15 cm		SUPERFICIE NATURALE (UGL)
Lunghezza e larghezza dei lati . Lenght and width of the sides Longuer et largeur de côtés . Länge und Breite Largo y ancho de los lados . Размеры сторон	ISO 10545-2		± 0,4 mm	± 0,3 <span> </span> %	± 1,0 mm	
Rettilineità degli spigoli . Straightness Equerrage des angles . Kantengeradheit Rectilineidad de las aristas . Кривизна сторон		± 0,4 mm	± 0,3 <span> </span> %	± 0,8 mm	Conforme . According to Conforme . Gemäss Conforme . Соответствует	
Ortogonalità** . Rectangularity** Orthogonalité . Rechtwinkligkeit Ortogonalidad . Косоугольность		± 0,4 mm	± 0,3 <span> </span> %	± 1,5 mm	Conforme . According to Conforme . Gemäss Conforme . Соответствует	
Planarità . Flatness Planéité . Planität Planaridad . Кривизна лицевой поверхности		± 0,6 mm	± 0,4 <span> </span> %	± 1,8 mm	Conforme . According to Conforme . Gemäss Conforme . Соответствует	
Spessore . Thickness Épaisseur . Stärke Espesor . Толщина	ISO 10545-2	± 0,5 mm	± 5 <span> </span> %	± 0,5 mm	Conforme . According to Conforme . Gemäss Conforme . Соответствует	Conforme . According to Conforme . Gemäss Conforme . Соответствует
Assorbimento % d'acqua . Water absorption Absorption d'eau . Wasseraufnahme Absorción % de agua . Водопоглощение	ISO 10545-3	Ev ≤ 0,5%			Conforme . According to Conforme . Gemäss Conforme . Соответствует	Conforme . According to Conforme . Gemäss Conforme . Соответствует
Determinazione della resistenza a flessione e della forza di rottura Flexion and break resistance Résistance à la flexion et à la force de ropture Biegefestigkeit und Bruchlast Resistencia a la flexión y carga de rotura Предел прочности при изгибе и разрушающая нагрузка	ISO 10545-4	Spessore ≥ 7,5 mm <span style="font-size: 2em;">[</span> S ≥ 1300 R ≥ 35 N/mm²			Conforme . According to Conforme . Gemäss Conforme . Соответствует	Conforme . According to Conforme . Gemäss Conforme . Соответствует
Determinazione della resistenza all'abrasione profonda (porcellanato non smaltato) UGL Deep Scratch Resistance (unglazed porcelain) UGL Résistance à l'abrasion profonde (grès cérame) UGL Tiefenverschleissbeständigkeit (unglasierte Feinsteinzeug) UGL Resistencia a la abrasión profunda (no esmaltados) UGL Стойкость к абразиву (UGL)	ISO 10545-6	≤ 175 mm3			Conforme . According to Conforme . Gemäss Conforme . Соответствует	Conforme . According to Conforme . Gemäss Conforme . Соответствует
Determinazione della resistenza all'abrasione superficiale PEI (porcellanato smaltato) GL Surface abrasion resistance PEI (glazed porcelain) GL Résistance à l'abrasion superficielle PEI (grès cérame émaillé) GL Beständigkeit gegen Abrieb PEI (glasierte Feinsteinzeug) GL Resistencia a la abrasión superficial PEI (esmaltados) GL Поверхностная износостойкость PEI (глазурованный керамогранит) GL	ISO 10545-7	<b>Classificazione PEI . Classification PEI</b> Classification PEI . Klassifizierung PEI Evaluación PEI . Классификация PEI			<b>Risultati delle prove disponibili in azienda</b> Test details can be obtained from the company	
Coefficiente di espansione termica lineare tra 20° e 100° C Linear thermal expansion 20°C to 100°C Dilatation thermique linéaire entre 20°C et 100°C Lineare Waerme-ausdehnung zwischen 20°C und 100°C Coeficiente de expansión térmica linear entre 20°C y 100°C Кoэффициент линейного теплового расширения	ISO 10545-8	<b>Metodo di prova disponibile . Test method available</b> Méthode d'assai disponible . Prüfverfahren verfügbar Método disponible . Используемый метод испытания			<b>Conforme . According to</b> Conforme . Gemäss Conforme . Соответствует	
Resistenza agli sbalzi termici . Thermal shock resistance Résistance aux écarts de température . Temperaturwechselbestaendigkeit Resistencia a los choques térmicos . Стойкость к перепаду температур	ISO 10545-9	<b>Metodo di prova disponibile . Test method available</b> Méthode d'assai disponible . Prüfverfahren verfügbar Método disponible . Используемый метод испытания			<b>Conforme . According to</b> Conforme . Gemäss Conforme . Соответствует	
Resistenza al gelo . Frost resistance Résistance au gel . Frostbeständigkeit Resistencia al hielo . Морозоустойчивость	ISO 10545-12	<b>Metodo di prova disponibile . Test method available</b> Méthode d'assai disponible . Prüfverfahren verfügbar Método disponible . Используемый метод испытания			<b>Conforme . According to</b> Conforme . Gemäss Conforme . Соответствует	
<b>Reazione al fuoco . Reaction to fire</b> Réaction au feu . Brandverhalten Reacción al fuego . Огнестойкость	-	<b>Classe A1 oppure A1<sub>s</sub> - Class A1 or A1<sub>s</sub></b> Klasse A1oder A1 <sub>s</sub> - Catégorie A1 ou A1 <sub>s</sub> - Klasse A1 o A1 <sub>s</sub>			A1-A1 <sub>s</sub>	
Determinazione della resistenza chimica . Chemical resistance Résistance chimique . Chemikalienbeständigkeit Resistencia a los productos químicos . Химическая стойкость	ISO 10545-13	<b>Classe UB minimo (UGL) - GB minimo (GL)</b> <b>Class UB min (UGL) - GB min (GL)</b> Clase UB min (UGL) - GB min (GL) Categorie UB min (UGL) - GB min (GL) Klasse UB min (UGL) - GB min (GL) Минимум класс UB (UGL) - GB min. (GL)			<b>UA ULA UHA</b>	<b>GA GLA -</b>
Determinazione della resistenza alle macchie . Resistance to staining Résistance aux taches . Beständigkeit gegen Fleckenbil Resistencia a las manchas . Устойчивость эмали к загрязнению	ISO 10545-14	<b>Classe 3 minimo . Class 3 min</b> Clase 3 min . Catégorie 3 min Klasse 3 min . Минимум 3 класс			<b>Conforme . According to</b> Conforme . Gemäss Conforme . Соответствует	
Resistenza allo scivolamento . Slip resistance Résistance au glissement . Bestimmung der Rutschemungsfähigkeit Antideslizamiento . Сопротивление скольжению	DIN 51130	<b>Classificazione R . Classification R</b> Evaluación R . Classification R Klassifizierung R . Классификация R			<b>R9</b>	-
Resistenza allo scivolamento - superfici bagnate calpestio a piedi scalzi Coefficient of friction - dry surfaces walking on barefoot Résistance au glissement - surfaces mouillées passage à pieds nus Bestimmung der Rutschemungsfähigkeit - nasse Oberfläche - Barfuß-gehen Resistencia al deslizamiento - superficie mojada pasaje con pies descalzos Сопротивление скольжению. Влажные полы, по которым ходят босыми ногами	DIN 51097	<b>Classificazione A B C . Classification A B C</b> Evaluación A B C . Classification A B C Klassifizierung A B C . Классификация A B C			<b>Conforme . According to</b> Conforme . Gemäss Conforme . Соответствует	-
Resistenza allo scivolamento - coefficiente di attrito dinamico ( DCOF ) Slip resistance - dynamic friction coefficient Résistance au glissement - résistance de frottement dynamique Bestimmung der Rutschemungsfähigkeit - dynamischer reibungskoeffizient Resistencia al deslizamiento - coeficiente de rozamiento dinámico Сопротивление скольжению. Коэффициент трения	BOT 3000 STANDARD ANSI A137.1:2012	≥ 0,42 wet			<b>Conforme . According to</b> Conforme . Gemäss Conforme . Соответствует	-
<b>GRADO DI VARIAZIONE CROMATICA</b> Ogni prodotto si caratterizza per un grado di stonalizzazione variabile da prodotto a prodotto, da colore a colore. Per stonalizzazione s'intende variazione di gradazione cromatica da piastrella a piastrella. DEGRÉ DE VARIATION CHROMATIQUE Chaque produit est caractérisé par un degré de nuance variable d'un produit à l'autre et d'une couleur à une autre. Par nuance, il faut entendre une variation de la gradation de couleur entre un carreau et un autre. GRAD DER FARBABWEICHUNG Jedes Produkt kennzeichnet sich durch einen bestimmten Grad an Marmorierung (Schattierung), der sich von Produkt zu Produkt, von Farbe zu Farbe unterscheiden kann. Unter Marmorierung versteht man den Grad der Farbänderung von Fliese zu Fliese. COLOR SHADE VARIATION Every product is characterised by colour-shading that can vary from one product to another and from one colour to another. When referring to colour-shading we refer to the chromatic variation of the tile surface. GRADO DE VARIAÇÃO CROMÁTICA Cada produto se caracteriza por el nivel de variación cromática que presentan sus baldosas, que cambia en función del producto y del color. РАЗБОС ЦВЕТОВОГО ТОНА Каждое изделие и каждый цвет отличается индивидуальной тональной неоднородностью. Под тональной неоднородностью понимается изменение цветовых нюансов от плитки к плитке.		<b>Prodotto con leggera variazione cromatica</b> Product with a slight chromatic variation Produit avec une légère variation de couleur Produkt mit leichter Farbänderung Producto con ligera variación cromática Изделие с лёгкой тональной неоднородностью				

### RIVESTIMENTO IN PASTA BIANCA

White body wall tiles - revêtements en pâte blanche - weißscherbiger wandfliesen - Revestimientos en pasta blanca - настенная плитка на белой глине

Norma di riferimento: **EN 14411 (ISO 13006) Allegato L Piastrelle di ceramica pressate a secco (Ev > 10 %)**

Reference standard: EN 14411 (ISO 13006) Appendix L Dry pressed ceramic tiles (Ev > 10 %) . Norme retenue: EN 14411 (ISO 13006) Annexe L Carreaux céramiques pressés à sec (Ev > 10 %)

Besugznorm: EN 14411 (ISO 13006) Anlage L Trockengepresste keramische Fliesen und Platten (Ev > 10 %) . Norma de referencia: EN 14411 (ISO 13006) Anexo L Baldosas de cerámica prensadas en seco (Ev > 10 %)  
Соответствует нормe EN 14411 Приложение L Керамические плитки, полученные путём прессования (водопоглощение Ev > 10 %)

## GRUPPO B III GL

CARATTERISTICHE TECNICHE . TECHNICAL CHARACTERISTICS Características técnicas . Technische eigenschaften Características técnicas . Технические характеристики	NORMA . NORMS Normes . Normen Normas . Стандарт	REQUISITI RICHIESTI . REQUIREMENTS Conditions requisés . Geforderte eigenschaften Valor solicitud . Значение, требуемое в соответствии с нормами			VALORE MEDIO SUPERGRES * Valeur moyenne . Average rating Durchschnittswert . среднее значение	
		RETTIFICATI	7 cm ≤ N < 15 cm	N > 15 cm		SUPERFICIE NATURALE (UGL)
Lunghezza e larghezza dei lati . Lenght and width of the sides Longuer et largeur de côtés . Länge und Breite Largo y ancho de los lados . Размеры сторон	ISO 10545-2		± 0,4 mm	± 0,3 <span> </span> %	± 1,0 mm	
Rettilineità degli spigoli . Straightness Equerrage des angles . Kantengeradheit Rectilineidad de las aristas . Кривизна сторон		± 0,4 mm	± 0,3 <span> </span> %	± 0,8 mm	Conforme . According to Conforme . Gemäss Conforme . Соответствует	
Ortogonalità** . Rectangularity** Orthogonalité . Rechtwinkligkeit Ortogonalidad . Косоугольность		± 0,4 mm	± 0,3 <span> </span> %	± 1,5 mm	Conforme . According to Conforme . Gemäss Conforme . Соответствует	
Planarità . Flatness Planéité . Planität Planaridad . Кривизна лицевой поверхности		± 0,6 mm	± 0,4 <span> </span> %	± 1,8 mm	Conforme . According to Conforme . Gemäss Conforme . Соответствует	
Spessore . Thickness Épaisseur . Stärke Espesor . Толщина	ISO 10545-2	± 0,5 mm	± 10%	± 0,5 mm	Conforme . According to Conforme . Gemäss Conforme . Соответствует	Conforme . According to Conforme . Gemäss Conforme . Соответствует
Assorbimento % d'acqua . Water absorption Absorption d'eau . Wasseraufnahme Absorción % de agua . Водопоглощение	ISO 10545-3	Ev > 10%			Conforme . According to Conforme . Gemäss Conforme . Соответствует	Conforme . According to Conforme . Gemäss Conforme . Соответствует
Determinazione della resistenza a flessione e della forza di rottura Flexion and break resistance Résistance à la flexion et à la force de ropture Biegefestigkeit und Bruchlast Resistencia a la flexión y carga de rotura Предел прочности при изгибе и разрушающая нагрузка	ISO 10545-4	Spessore ≥ 7,5 mm <span style="font-size: 2em;">[</span> S ≥ 600 N R ≥ 15 N/mm²			Conforme . According to Conforme . Gemäss Conforme . Соответствует	Conforme . According to Conforme . Gemäss Conforme . Соответствует
Determinazione della resistenza alla cavillo Crazing resistance Résistance aux craquelures Haarß-Beständigkeit Resistencia al cuarteado Устойчивость эмали к краquelору (старению)	ISO 10545-11	<b>Richiesta . Required</b> Requise . Erforderlich Exigida . Согласно нормe			Conforme . According to Conforme . Gemäss Conforme . Соответствует	Conforme . According to Conforme . Gemäss Conforme . Соответствует
<b>Reazione al fuoco . Reaction to fire</b> Réaction au feu . Brandverhalten Reacción al fuego . Огнестойкость	-	<b>Classe A1 oppure A1<sub>s</sub> - Class A1 or A1<sub>s</sub></b> Klasse A1oder A1 <sub>s</sub> - Catégorie A1 ou A1 <sub>s</sub> - Klasse A1 o A1 <sub>s</sub>			A1	
Determinazione della resistenza chimica . Chemical resistance Résistance chimique . Chemikalienbeständigkeit Resistencia a los productos químicos . Химическая стойкость	ISO 10545-13	<b>Classe GB minimo . Class GB min</b> Categorie GB min . Klasse GB min Clase GB min . Минимум GB класс			<b>Conforme . According to</b> Conforme . Gemäss Conforme . Соответствует	
Determinazione della resistenza alle macchie . Resistance to staining Résistance aux taches . Beständigkeit gegen Fleckenbil Resistencia a las manchas . Устойчивость эмали к загрязнению	ISO 10545-14	<b>Classe 3 minimo . Class 3 min</b> Clase 3 min . Catégorie 3 min Klasse 3 min . Минимум 3 класс			<b>Conforme . According to</b> Conforme . Gemäss Conforme . Соответствует	

**\* Valori riferiti ai fondi. Le caratteristiche tecniche fanno riferimento al formato nominale delle piastrelle espresso in mm.** - These values refer to the bottoms. The technical characteristics refer to the nominal size of tiles expressed in mm.

Valeurs se référant aux fonds. Les caractéristiques techniques se réfèrent au format nominal des carreaux exprimé en mm. - Werte bezogen auf Grundfliesen. Die Angaben beziehen sich auf die Nenngröße der Fliesen in mm.

Valores referidos a los fondos. Las características técnicas se refieren al formato nominal de las baldosas expresado en mm. - Показатели относятся к фоновой плитке. Технические характеристики относятся к номинальному формату плиток, выраженному в мм.

**Se non indicato diversamente, i valori delle prove tecniche si riferiscono alla superficie naturale.** - Unless otherwise indicated, the values of technical tests refer to the natural surface finish. - Sauf indication contraire, les valeurs des tests techniques se rapportent à la surface naturelle. - Wenn nicht anders angegeben beziehen sich die Werte der technischen Tests auf die natürliche Oberfläche. - Los valores de las pruebas técnicas se refieren a la superficie natural (si no es indicada una situación diferente).

Если не указано иное, результаты испытаний относятся к натуральной поверхности.

**\*\* Per piastrelle rettangolari che abbiano il lato maggiore L ≥ 60 cm, e rapporto tra i lati ≥ 3, la misurazione dell'ortogonalità deve venire condotta solo sul lato corto.** - For rectangular tiles with longest side L ≥ 60 cm and a ratio length/width LW ≥ 3, the measurement of orthogonality should only be carried out on short edges. - Pour les carreaux rectangulaires qui ont le côté le plus long L ≥ 60 cm, et le rapport entre les côtés ≥ 3, la mesure de l'orthogonalité se fait seulement sur le côté le plus court. - Bei rechteckigen Fliesen, mit der längsten Seite L ≥ 60 cm und einem Seitenverhältnis von ≥ 3 darf die Messung der Rechteckigkeit nur an der kurzen Seite durchgeführt werden. - Para las baldosas rectangulares con lado mayor L ≥ 60 cm y proporción entre los lados ≥ 3, la medición de ortogonalidad tiene que ser efectuada sólo en el lado corto. - Для прямоугольных плиток с более длинной гранью L ≥ 60 см и соотношением граней ≥ 3 измерение ортогональности выполняется только по короткой грани.

I dati e le informazioni riportate nel presente catalogo sono aggiornate al momento della stampa e potrebbero subire successive correzioni e/o modifiche. Verificare sempre l'ultima edizione disponibile confrontando la data riportata nell'ultima pagina della versione cartacea, con quella indicata nel pdf del catalogo scaricabile dal sito [www.supergres.com](http://www.supergres.com)

I colori e le caratteristiche estetiche dei prodotti sono indicativi e si avvicinano quanto più possibile a quelli reali nei limiti consentiti dai processi di stampa.

Data and information reported in this catalogue are updated at the moment of catalogue printing therefore they may be subject to subsequent corrections and/or amendments. Always check the latest available issue and compare the date reported on the last page of the hard-paper copy of the catalogue with that stated in the pdf. format downloadable on website [www.supergres.com](http://www.supergres.com)

The colours and aesthetic features of products are indicative and reproduce, as close as possible, the real colours and features taking into consideration the restrictions of printing processes.

© Copyright 2016 Ceramiche Supergres Casalgrande (Reggio Emilia) - Italy  
Pubblicato da Ceramiche Supergres. Strada Statale 467, n° 34 - 42013 Casalgrande (RE) Italy  
Settembre 2016  
Progetto, direzione e coordinamento a cura dell'ufficio marketing Ceramiche Supergres

© Copyright 2016 by Ceramiche Supergres Casalgrande (Reggio Emilia) - Italy  
Published by Ceramiche Supergres. Strada Statale 467, n° 34 - 42013 Casalgrande (RE) Italy  
September 2016  
Project, management and co-ordination by marketing Ceramiche Supergres

## CERAMICHE SUPERGRES

Finito di stampare a Brescia (BS) nel mese di Gennaio 2018 da Tipolitografia Pagani per conto di Ceramiche Supergres  
Strada Statale 467, n° 34 - 42013 Casalgrande (RE) Italy.

I prodotti, i marchi e le immagini riprodotte nel presente catalogo sono tutelati ai sensi della normativa vigente in materia di proprietà intellettuale.  
Ogni violazione degli stessi verrà perseguita a norma di legge.

Printed in Brescia (BS) in the month of January 2018 by Tipolitografia Pagani on behalf of Ceramiche Supergres  
Strada Statale 467, n° 34 - 42013 Casalgrande (RE) Italy

All products, trade-marks and photographs reproduced in this catalogue are subject to all existing intellectual property laws.  
Any breach thereof will be dealt with under the provisions provided by such law.



CERAMICHE  
**SUPERGRES**

Office: Strada Statale 467, 34  
42013 Casalgrande (RE) Italy  
Ph. +39 0522 997411  
Fax Export +39 0522 997415  
Fax Italia +39 0522 997494

Warehouse: Via dell'Industria, 1 - Villaggio Macina  
42013 Salvaterra di Casalgrande (RE) Italy

[info@supergres.com](mailto:info@supergres.com) . [www.supergres.com](http://www.supergres.com)