

/SKYLINE



dESIGN
SUR-
FACES

4 SKYLINE



b

b-c/ DARK BROWN R - 26x160 cm/10"x63"



c



d-e/ floor: GREY R - 20,2x122,2 cm/8"x48"
wall: GREY R - 30,4x122,2 cm/12"x48"
LE RESINE CENERE R - 122,2x122,2 cm/ 48"x48"

f-g/ floor: NATIVE R - 26x160 cm/10"x63"
wall: TEAK NATIVE R - 30,4x122,2 cm/12"x48"
UNIVERSAL MIRABELL R - 61x122,2 cm/24"x48"



f



9

DESIGN SURFACES

NATIVE

DARK BROWN

WHITE

GREY

NATIVE

O5X1	26x160 cm 10"x63" - R	A90
O0V3	30,4x122,2 cm 12"x48" - R	A120
O4X3	30,4x122,2 cm 12"x48" TEAK - R	A121
O0V0	20,2x122,2 cm 8"x48" - R	A30
O4X8	20,2x122,2 cm 8"x48" OUTDOOR - R	A31
O5W1	22x90 cm 9"x36" - R	A70
O4W7	15x90 cm 6"x36" - R	A20
O6W9	30x122 cm 12"x48" - F-F-E R	A150



DARK BROWN

O5X2	26x160 cm 10"x63" - R	A90
O0V1	30,4x122,2 cm 12"x48" - R	A120
O4X4	30,4x122,2 cm 12"x48" TEAK - R	A121
O9U8	20,2x122,2 cm 8"x48" - R	A30
O4X7	20,2x122,2 cm 8"x48" OUTDOOR - R	A31
O4W9	22x90 cm 9"x36" - R	A70
O4W5	15x90 cm 6"x36" - R	A20



WHITE

O5X3	26x160 cm 10"x63" - R	A90
O0V2	30,4x122,2 cm 12"x48" - R	A120
O4X5	30,4x122,2 cm 12"x48" TEAK - R	A121
O9U9	20,2x122,2 cm 8"x48" - R	A30
O4X9	20,2x122,2 cm 8"x48" OUTDOOR - R	A31
O5W0	22x90 cm 9"x36" - R	A70
O4W6	15x90 cm 6"x36" - R	A20
O9W6	30x122 cm 12"x48" - F-F-E R	A150



GREY

O5X4	26x160 cm 10"x63" - R	A90
O2V1	30,4x122,2 cm 12"x48" - R	A120
O4X6	30,4x122,2 cm 12"x48" TEAK - R	A121
O2V2	20,2x122,2 cm 8"x48" - R	A30
O5X0	20,2x122,2 cm 8"x48" OUTDOOR - R	A31
O5W2	22x90 cm 9"x36" - R	A70
O4W8	15x90 cm 6"x36" - R	A20

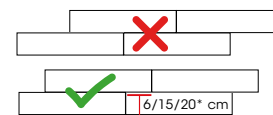

6/15/20* cm

- * distanza 6/15/20 cm a correre
- * placed 6/15/20 cm apart, one next to another
- * distance 6/15/20 cm à joints coupés
- * abstand 6/15/20 cm bei fortlaufender Verlegung

Si consiglia la posa sfalsata irregolare del prodotto onde evitare problemi di planarità.
 Si consiglia inoltre l'utilizzo dei distanziatori livellanti.
 It is advisable to stagger the product irregularly when laying it to avoid problems in flatness.
 We also recommend the use of leveling wedges.
 Nous vous conseillons d'adopter la pose irrégulière à joints décalés pour le produit afin d'éviter les problèmes de planéité.
 Nous recommandons également l'utilisation des croissillons nivelant.
 Empfehlen wir die unregelmäßige versetzte Verlegung dieser Fliese, um Probleme mit der Ebenföchigkeit zu vermeiden.
 Wir empfehlen auch die Verwendung von nivellierenden Abstandhaltern.

Decorsi / Decors / Décors / Dekors



chevron SX-DX - 7,2x40 cm 3"x16"



CHEVRON NATIVE

- P0C9 7,2x40 cm 3"x16" SX - R A00
- P1C0 7,2x40 cm 3"x16" DX - R A00



CHEVRON DARK BROWN

- P1C2 7,2x40 cm 3"x16" SX - R A00
- P1C1 7,2x40 cm 3"x16" DX - R A00



CHEVRON WHITE

- P1C3 7,2x40 cm 3"x16" SX - R A00
- P1C4 7,2x40 cm 3"x16" DX - R A00



CHEVRON GREY

- P1C6 7,2x40 cm 3"x16" SX - R A00
- P1C5 7,2x40 cm 3"x16" DX - R A00

teak - 9 bacchette



TEAK NATIVE

O4X3 30,4x122,2 cm 12"x48" TEAK - R A121



TEAK DARK BROWN

O4X4 30,4x122,2 cm 12"x48" TEAK - R A121





TEAK WHITE

O4X5 30,4x122,2 cm 12"x48" TEAK - R A121



TEAK GREY

O4X6 30,4x122,2 cm 12"x48" TEAK - R A121

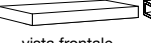
Pezzi Speciali / Special Pieces / Pièces Spéciales / Formteile	 battiscopa 6,5x122,2 cm 2 1/2"x48" R P05	 elemento "L" monolitico outdoor 15x30x4 cm 6"x12"x1 3/4" R P50	 gradino costa retta 34x122,2x4 cm 13"x48"x1 3/4" R P32	 vista frontale angolare costa retta dx/sx 34x122,2x4 cm 13"x48"x1 3/4" R P41
	NATIVE	●	●	●
DARK BROWN	●	●	●	●
WHITE	●	●	●	●
GREY	●	●	●	●

Note / Notes / Notes / Anmerkungen
 I battiscopa e gli elementi "L" vengono venduti a pz. e a scatola completa. Tutti gli altri pezzi speciali vengono venduti al pezzo. I gradini vengono prodotti solo su ordinazione (tempo minimo di consegna 20 gg lavorativi).
 All skirting and monolithic L elements, priced per piece, are sold in full box. All other special trims are sold by piece. Steps are produced only on request (minimum delivery terms of 20 days).
 Les plinthes et élément "L" sont vendues la pièce et par boîte complète. Les autres pièces spéciales sont vendus la pièce. Le plat de marche sont produit sur demande (délai minimum de 20 jours).
 Die Sockelleisten und Stufen werden pro Stk. und Vollen Kartons verkauft. Stufen und Stufenecken werden nur auf Bestellung produziert (Lieferzeiten mindesten 20 arbeitstagen ab Auftragserteilung).

effetto legno / wood-look / effet bois / holzoptik
 Colori / Colours / Couleurs / Farben



Formati / Sizes / Formats / Formate

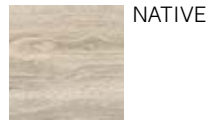

NATIVE



WHITE



R - 30x122 cm . 12"x48" ± 20 mm FP2 - R11

R: Rettificato / Rectified

Formati / Sizes / Formats / Formate	R - 30x122 cm 12"x48" ± 20 mm FP2 R11
NATIVE	●
WHITE	●



i/NATIVE FP2 R - 30x122 cm/12"x48"

NATIVE

O6W9 30x122 cm 12"x48"-FP2-R A150



WHITE

O9W6 30x122 cm 12"x48"-FP2-R A150



FP2 Pezzi Speciali / Special Pieces / Pièces Spéciales / Formteile	 elemento "L" 30x122x5 cm 12"x48" x2" R	 angolare elemento "L" SX/DX 30x122x5 cm 12"x48" x2" R	 griglia 30x61 cm 12"x24" R	 angolo SX angolo DX griglia angolo 30x61 cm 12"x24" R
	P102	P105	P106B	P109A COPPIA
NATIVE	●	●	●	●
WHITE	●	●	●	●
	 round lineare 30x122 cm 12"x48" R	 round angolare 30x122 cm 12"x48" R	 angolo SX angolo DX angolo bordo toro 30x122 cm 12"x48" R	
	P112A	P113C COPPIA	P116	
NATIVE	●	●	●	
WHITE	●	●	●	

Note - Notes - Notes - Anmerkungen
 I pezzi speciali FP2 vengono venduti al pezzo e solo su ordinazione (tempo minimo di consegna 20 gg lavorativi dall'ordine).
 The special pieces FP2 are sold by piece and only on request (minimum delivery time 20 working days from date of order).
 Les pièces spéciales FP2 sont vendus à la pièce et uniquement sur commande (délai minimum de livraison 20 jours ouvrés à partir de la commande).
 Spezial Teile FP2 sind pro Stück verkauft und nur auf Bestellungen produziert. (Lieferzeiten mindesten 20 arbeitstage ab Auftragbestätigung)

TABELLA PESI ED IMBALLI

Sizes weight and packaging / Mesures poids et emballages / Tabelle der Gewichte und Verpackungen

formati / sizes / tailles / formate /		pz. x box	mq. x box	box x pal.	mq. x pal.	kg. x mq	kg. x box	kg. x pal.	
RETTIFICATI / RECTIFIED (R)									
30,4x122,2 cm 12"x48" R	9,5 mm	4	1,49	36	53,64	19,98	29,77	1090	94x120x75
30,4x122,2 cm 12"x48" R TEAK	9,5 mm	2	0,74	57	42,18	19,98	14,79	1153	94x120x65
26x160 cm 10"x63" R	9,5 mm	4	1,66	27	44,82	21,08	35,00	950	91x171x60
22x90 cm 9"x36" R	9 mm	5	0,99	66	65,34	20,02	19,81	1325	94x120x85
20,2x122,2 cm 8"x48" R	9,5 mm	4	0,99	48	47,52	20,33	20,12	980	80x120x75
15x90 cm 6"x36" R	9,5 mm	8	1,08	56	60,48	19,30	20,84	1185	94x120x75
SPESSORATI / EXTRA THICK (R) 									
30x122 cm 12"x48" R	20 mm	2	0,73	36	26,28	41,50	30,29	1117	94x120x74
pezzi speciali / special pieces / pièces spéciales / fornteile /									
6,5x122,2 cm 2"x48" battiscopa rettificato		10					12,50		

Note / Notes / Notes / Anmerkungen

I battiscopa e gli elementi "L" vengono venduti a pz. e a scatola completa. Tutti gli altri pezzi speciali vengono venduti al pezzo. I gradini vengono prodotti solo su ordinazione (tempo minimo di consegna 20 gg lavorativi).
 All skirting and monolithic L elements, priced per piece, are sold in full box. All other special trims are sold by piece. Steps are produced only on request (minimum delivery terms of 20 days).
 Les plinthes et élément "L" sont vendues la pièce et par boîte complète. Les autres pièces spéciales sont vendus la pièce. Le plat de marche sont produit sur demande (délai minimum de 20 jours).
 Die Sockelleisten und Stufen werden pro Stk. und Vollen Kartons verkauft. Stufen und Stufenecken werden nur auf Bestellung produziert (Lieferzeiten mindesten 20 arbeitstagen ab Auftragserteilung).

SIMBOLOGIA CARATTERISTICHE TECNICHE - GRÈS PORCELLANATO /

Symboles technical characteristics - porcelain stoneware / Symboles des caracteristiques techniques - grès cérame / Symbole technischen eigenschaften - feinsteinzeug



CARATTERISTICHE TECNICHE TECHNICAL CHARACTERISTICS CARACTÉRISTIQUES TECHNIQUES TECHNISCHE MERKMALE	NORMA DI RIFERIMENTO REFERENCE STANDARD NORME DE REFERENCE PRÜFMETHODE	VALORE RICHIESTO REQUIRED VALUE VALEUR REQUISE SOLLWERT	VALORE MEDIO TUSCANIA AV. TUSCANIA VALUE VALEUR MOYENNE TUSCANIA MITTLERER TUSCANIA-WERT
---	---	--	---

	DIMENSIONI DIMENSIONS DIMENSIONS ABMESSUNGEN	ISO 10545-2	CONFORME COMPLIANT CONFORME KONFORM	CONFORME COMPLIANT CONFORME KONFORM
	ASSORBIMENTO D'ACQUA WATER ABSORPTION ABSORPTION D'EAU WASSERAUFNAHME	ISO 10545-3	≤ 0,5 %	CONFORME COMPLIANT CONFORME KONFORM
	RESISTENZA A FLESSIONE MODULUS OF RUPTURE RESISTANCE A LA FLEXION BIEGEFESTIGKEIT	ISO 10545-4	MODULUS OF RUPTURE R ≥35 N/MM ² BREAKING STRENGTH S ≥1300 N	CONFORME COMPLIANT CONFORME KONFORM
	RESISTENZA ALL'ABRASIONE ABRASION RESISTANCE RÉSISTANCE À L'ABRASION ABRIEBBESTÄNDIGKEIT	ISO 10545-7	PEI SOLO PER PIASTRELLE SMALTATE ONLY FOR GLAZED TILES	
	DILATAZIONE TERMICA LINEARE LINEAR THERMAL EXPANSION DILATATION THERMIQUE LINEAIRE LINEARE WÄRMEAUSSDEHNUNG	ISO 10545-8	≤ 9x10 ⁻⁵ °C ⁻¹	CONFORME COMPLIANT CONFORME KONFORM
	RESISTENZA AGLI SBALZI TERMICI THERMAL SHOCK RESISTANCE RESISTANCE AUX ECARTS DE TEMPERATURE ITEMPERATURWECHSELBESTÄNDIGKEIT	ISO 10545-9	RESISTENTE RESISTANT RESISTANT BESTÄNDIG	RESISTENTE RESISTANT RESISTANT BESTÄNDIG
	RESISTENZA AL GELO FROST RESISTANCE RESISTANCE AU GEL FROSTBESTÄNDIGKEIT	ISO 10545-12	RESISTENTE RESISTANT RESISTANT BESTÄNDIG	RESISTENTE RESISTANT RESISTANT BESTÄNDIG
	RESISTENZA AGLI ACIDI ED ALLE BASI ACID AND ALKALI RESISTANCE RESISTANCE AUX ACIDES ET AUX BASES SÄURE- UND LAUGENBESTÄNDIGKEIT	ISO 10545-13	CLASS GB MIN.	LOW CONCENTRATION GLA HIGH CONCENTRATION GHA
	RESISTENZA ALL'ATTACCO CHIMICO CHEMICAL RESISTANCE RESISTANCE À L'ATTAQUE CHEMIQUE CHEMISCHE BESTÄNDIGKEIT	ISO 10545-13	CLASS GB MIN.	GA
	RESISTENZA ALLE MACCHIE STAIN RESISTANCE RESISTANCE AU TACHES FLECKENBESTÄNDIGKEIT	ISO 10545-14	CLASS 3 MIN.	5
	COEFFICIENTE DI ATTRITO (SCIVOLOSITÀ) FRICTION COEFFICIENT (SLIPPERINESS) COEFFICIENT DE FRICTION (GLISSEMENT) REIBUNGSKOEFFIZIENT (RUTSCHIGKEIT)	BCR - ITALIA DM DEL 14-06-89	ASTM - USA ASTM C1028	DIN - GERMANIA DIN 51130
		DRY RUBBER 0,62	WET RUBBER 0,51	DRY LEATHER 0,62
			DRY NEOLYTHE 0,69	WET NEOLYTHE 0,62
				R10 - R11 outdoor/FP2 ZH 1/571

THE PRODUCTS HAVING AN ABSORPTION < 0,5% ARE CLASSIFIED ACCORDING THE UNI CEN STANDARDS "FULLY VITRIFIED TILES" AND ACCORDING TO THE ASTM STANDARDS "IMPERVIOUS TILES"

Le informazioni contenute nel presente catalogo sono il più possibile esatte, ma non sono da ritenersi vincolanti. Per esigenze di produzione l'Azienda si riserva il diritto di apportare eventuali modifiche che si rendessero necessarie. Peso, colori e misure sono soggetti alle inevitabili variazioni tipiche del processo di cottura della ceramica. I colori e gli effetti riportati sul presente catalogo sono indicativi per i limiti consentiti dalla stampa; per questo non possono essere vincolanti e costituire base per eventuali contestazioni.

The information contained in this catalogue is as accurate as possible, but cannot be considered as legally binding. The Company reserves the right to make any modifications that become necessary due to production requirements. Weight, colours and dimensions are subject to the inevitable variations typical of the ceramic firing process. Colours and aesthetic effects shown on this catalogue should be considered indicative and approximate as a result of printing process limits. Possible variations may occur and can not be at the base of any claim.

Les informations reprises dans ce catalogue sont exactes, mais elles n'engagent aucunement notre Société du point de vue légal. Pour des exigences de production la Société se réserve le droit d'apporter toutes les dimensions sont assujettis aux variations typiques du processus de cuisson de la céramique. Les couleurs et les effets présentés dans ce catalogue sont indicatifs dans la mesure permise par la presse, ce qui explique pourquoi ils ne peuvent pas être obligatoire et constituer la base d'un éventuel désaccord.

Die Informationen des vorliegenden Katalogs sind so exakt wie möglich, sind jedoch nicht als gesetzlich verbindlich zu betrachten. Aus Fertigungsgründen behält die Firma sich das Recht vor, eventuell notwendige Änderungen vorzunehmen. Veränderungen, die für den Brennvorgang von Keramikprodukten typisch sind. Die in diesem Katalog gezeigten Farben und Effekte sind Richtwerte, soweit durch die Presse, die ist, warum sie nicht bindend und stellen die Grundlage für eine Meinungsverschiedenheit gestattet.

Credit:

Marketing:
Tuscania

Progetto Grafico:
EUREKA

TUSCANIA[®]
ceramiche



/SKYLINE



tuscaniagres.it

Tuscania S.p.A.

Via Giardini Sud, 4603
41028 Serramazzoni (Mo) - Italia
Tel. +39 0536.952399
Fax +39 0536.954716
info@tuscaniagres.it
www.tuscaniagres.it

